

infiniti

DESIGN & DETAILS

**SIT AROUND
[Y]OUR WORLD**

Catalogue 2025

infiniti

infinitidesign.it

[1]



infiniti

IT - infiniti progetta e produce complementi d'arredo caratterizzati da design contemporaneo e innovazione tecnologica. Nato nel 2008 il brand fa parte del gruppo industriale OMP Group, che dal 1983 progetta e produce componenti metallici per la casa e il mondo del contract.

Inizialmente orientato alla creazione di prodotti per il mercato domestico, con il passare del tempo il brand allarga il raggio d'azione all'ambito corporativo e Horeca, grazie alla grande forza produttiva del Gruppo di cui fa parte, che si esprime in centinaia di prodotti a catalogo e in infinite possibilità di personalizzazione dei progetti.

Dalla casa madre infiniti eredita, infatti, anche la capacità di tessere relazioni con general contractor, architetti e interior designer per dare forma a qualsiasi tipo di realizzazione dall'ambito residenziale al corporate, dall'hospitality alla ristorazione, senza dimenticare luoghi pubblici come aeroporti, stazioni e centri commerciali, ma anche enti educativi, culturali e istituzionali.

WHO WE ARE

EN - infiniti designs and produces furniture accessories characterized by contemporary design and technological innovation. Founded in 2008, the brand is part of the OMP Group, an industrial group that has been designing and manufacturing metal components for the home and contract sector since 1983.

Initially focused on creating products for the domestic market, over time the brand has expanded its scope to include corporate and Horeca (Hotel, Restaurant, Catering) sectors, thanks to the significant production strength of the Group it belongs to. This is reflected in hundreds of catalog products and countless customization options for projects.

From its parent company, infiniti also inherits the ability to build relationships with general contractors, architects, and interior designers to shape any type of project, from residential to corporate, hospitality to dining, and even public spaces such as airports, train stations, and shopping centers, as well as educational, cultural, and institutional entities.



IT - Gli headquarter di infiniti si trovano in Italia, nel cuore dell'operoso Nord Est, a Castello di Godego. Vicino alla sede si trovano città ricche di storia come Venezia, Padova, Bassano del Grappa, Treviso.



EN - infiniti's headquarter are located in Italy, in the heart of the industrious North East, in Castello di Godego. Close to the headquarter are cities rich in history such as Venice, Padua, Bassano del Grappa and Treviso.

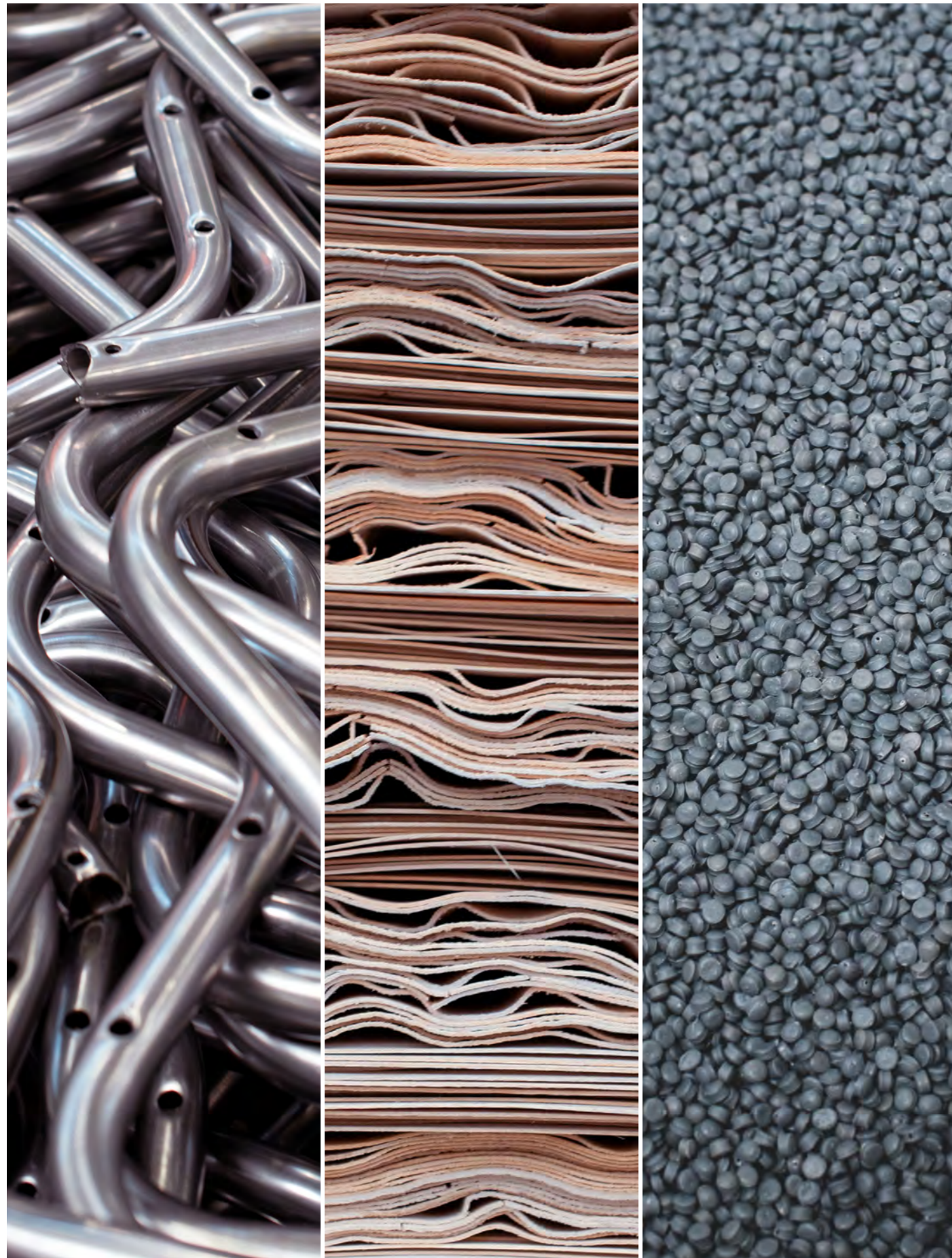

[6]

IT - Ferro, plastica e legno sono i tre capisaldi della materioteca infiniti e tutte le lavorazioni avvengono all'interno dei reparti produttivi aziendali. Il legno curvato è tra i miglior know how del brand, così come la produzione di ferro e plastica che vengono lavorati in loco. È grazie a questa grande potenza produttiva che infiniti può offrire un'ampiezza di gamma che consente di andare incontro a qualsiasi esigenza di personalizzazione o quantità.

EN - Metal, plastic, and wood are the three core materials in infiniti's material library, and all processing takes place within the company's production departments. 3D curved wood is one of the brand's greatest areas of expertise, as is the production of metal and plastic, which are all processed on-site. It is thanks to this substantial production capacity that infiniti can offer a wide range of products to meet any customization or quantity requirements.



[7]



[INDEX]

[SEATING]	12	Harmo	115	Peb	217
Canova	15	Seame	125	Kram	225
Tondina	25	Woodstock	133	Sys	233
Feluca	35	Porta Venezia	141	Waffle	241
Skol	43	Settesusette	149	Museum	249
Takumi	51	Round&Round	157	[TABLES]	256
Ruelle	59	Round&Roll	165	Versable	259
GT01	67	Flip	173	Record	267
Pure Loop Mono	75	Klejn	181	Rim	275
Loop Mono	83	Flink	191	Jit	283
Loop 3D	91	Pure Loop Mini	199	Feluca Table	291
Relief	99	[LOUNGE&SOFA]	206	Flink Table	299
Sicla	107	BomBom	209		

[2025] - Catalogue

COLLECTIONS

IT - La collezione infiniti propone un'ampia selezione di sedute e tavoli pensati per ambienti corporate, sia indoor che outdoor. Dalle sedie alle panche, dagli sgabelli ai sistemi modulari, ogni prodotto è progettato per rispondere in modo efficiente e coerente alle esigenze di contesti diversi. Soluzioni versatili, caratterizzate da un equilibrio tra estetica e funzionalità, capaci di adattarsi a scenari semplici o complessi con la stessa naturale armonia.

EN - The infiniti collection offers a wide selection of seating and tables designed for corporate environments, both indoor and outdoor. From chairs to benches, from stools to modular units, each product is designed to respond efficiently and consistently to the needs of different contexts.

Versatile solutions, characterized by a balance between aesthetics and functionality, capable of adapting to simple or complex scenarios with the same natural harmony.



SEATING

HERI- TAGGE



CANOVA

[CHAIR]

Design: Claus Breinholt

IT - Canova reinterpreta l'eleganza delle sedie in legno con un linguaggio contemporaneo. La sua silhouette morbida richiama il passato, ma sorprende per la leggerezza del polipropilene colorato. Un monoblocco accogliente, arricchito da un cuscino imbottito o da un pannello in legno che ne esalta la matericità. La versione sgabello amplia le possibilità compositive, creando abbinamenti armoniosi tra forme e colori.

EN - Canova reinterprets the elegance of wood chairs with a modern twist. Its rounded shape is reminiscent of the past, but it is surprisingly light thanks to the use of polypropylene in different colours. An inviting mono-block shell is made more comfortable with a padded cushion or a wood panel, adding to the feel of the natural materials. The stool version increases the number of ways it can be arranged, making it possible to create coordinated colour and shape combinations.







CANOVA

[TECHNICAL DETAILS]

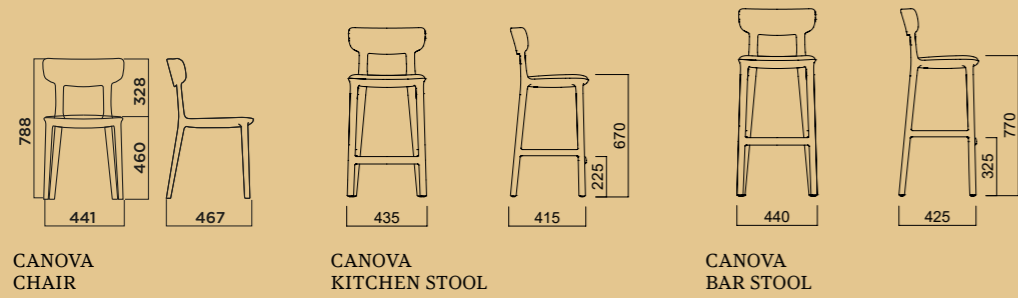

Esempi di combinazioni finiture / Examples of finish combinations:



Cipria/Anthracite stained plywood ash



Cipria/Anthracite stained plywood ash



Cipria/Anthracite stained plywood ash



Marsala/Hero 2 HE0312



Marsala/Hero 2 HE0312



Marsala/Hero 2 HE0312



Off-white/Natural plywood ash



Off-white/Natural plywood ash



Off-white/Natural plywood ash



Reed green/Hero Heather HH0463



Reed green/Hero Heather HH0463



Reed green/Hero Heather HH0463

SINUO- SITY



[24]

TONDINA

[CHAIR]

Design: Favaretto&Partners

IT - Tondina è una collezione trasversale, dove linee morbide incontrano materiali diversi per adattarsi a ogni ambiente. Tondina Pop ha una scocca in polipropilene colorato, mentre Slim reinterpreta l'intreccio anni '50 con una trama traforata ideale per l'outdoor. Tondina Fat, imbottita e accogliente, offre un comfort avvolgente, mentre la versione in legno, la prima della famiglia, esalta le venature naturali e si declina in sedia, sgabello e Lounge. Le varianti in legno e Pop possono essere tappezzate, aggiungendo un ulteriore livello di personalizzazione.

EN - A wide-ranging collection, Tondina fuses soft lines with different materials for use in any environment. Tondina Pop features a coloured polypropylene shell, while Slim revisits the open weave typical of the 1950s, making it ideal for outdoor use. Tondina Fat, upholstered and cosy, offers all-enveloping comfort, while the wood version, the forerunner of the range, exalts its natural grain and is available as a chair, stool and Lounge chair. The wood and Pop options can be upholstered, for a more personal touch.

[25]







TONDINA

[TECHNICAL DETAILS]

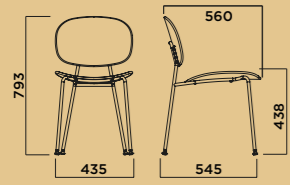

TONDINA

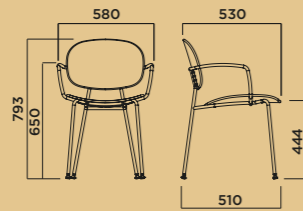

TONDINA WITH ARMS

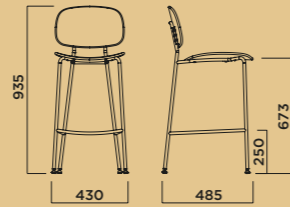

TONDINA KITCHEN STOOL

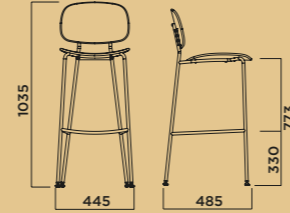

TONDINA BAR STOOL

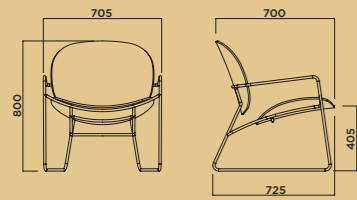

TONDINA LOUNGE

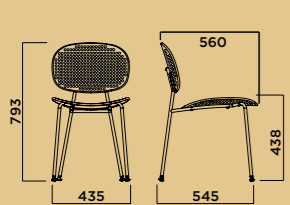

TONDINA SLIM

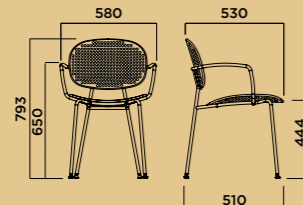

TONDINA SLIM WITH ARMS

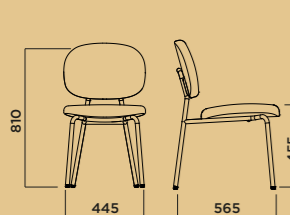

TONDINA FAT

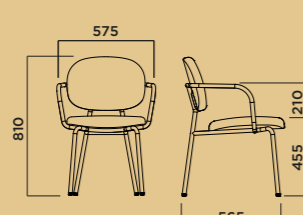

TONDINA FAT WITH ARMS

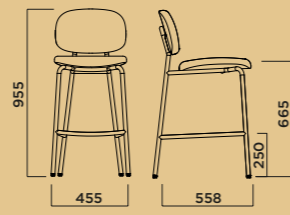

TONDINA FAT KITCHEN STOOL

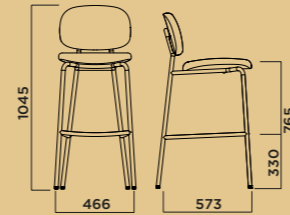

TONDINA FAT BAR STOOL

Esempi di combinazioni finiture / Examples of finish combinations:



Matt black/Natural plywood oak



Matt black/Natural plywood oak



Matt black/Natural plywood oak



Ochre yellow/Ochre yellow



Ochre yellow/Ochre yellow



Ochre yellow/Ochre yellow



Reed green/Reed green



Reed green/Reed green



Reed green/Reed green



Antique brass/Hero Heather HH0233



Antique brass/Hero Heather HH0233



Antique brass/Hero Heather HH0233

ELE- GANCE



FELUCA

[CHAIR]

Design: BrogliatoTraverso

IT - Feluca riprende la silhouette elegante dell'omonimo copricapo del XVIII secolo, con uno schienale curvato che dona movimento e raffinatezza alla struttura, mentre il telaio ellittico valorizza il design distintivo della collezione. Feluca Pop reinterpreta la seduta in polipropilene ed è ideale anche per l'outdoor, mentre Feluca Organic unisce la scocca in plastica alla naturalezza del legno. Disponibile in versione sedia e sgabello, si veste di abbinamenti tono su tono o contrasti cromatici che ne esaltano la versatilità.

EN - Feluca is inspired by the elegant silhouette of the eighteenth-century headdress bearing the same name ("becorn hat" in English), with a curved back that imbues the structure with movement and refinement, while the elliptical frame accentuates the collection's signature design. Feluca Pop reinterprets the polypropylene chair and is suitable for outdoor use, while Feluca Organic combines a plastic frame with the appeal of natural wood. Available in chair and stool versions, it can be combined in tone-on-tone or contrasting colours for maximum versatility.

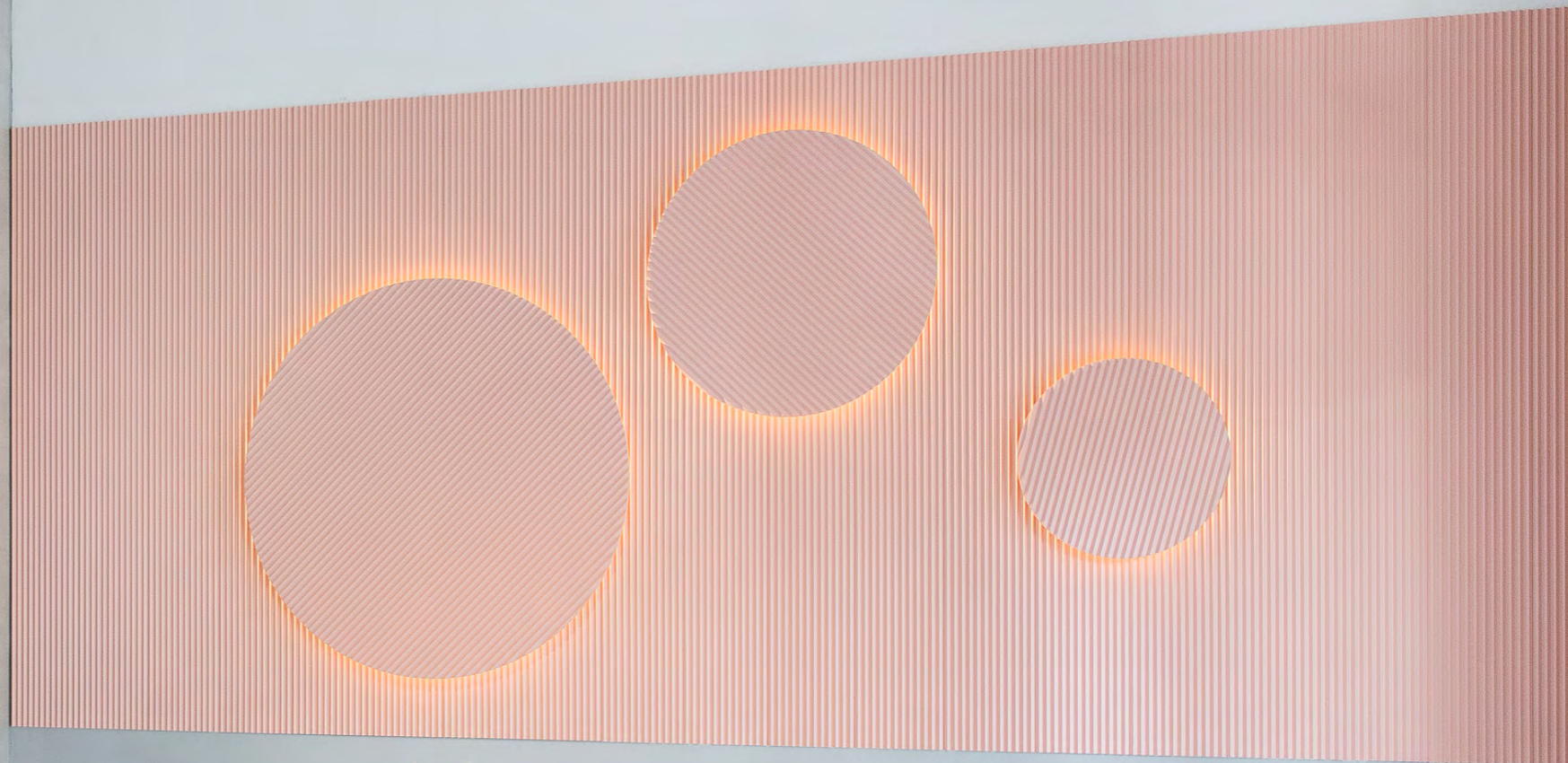



FELUCA

[TECHNICAL DETAILS]

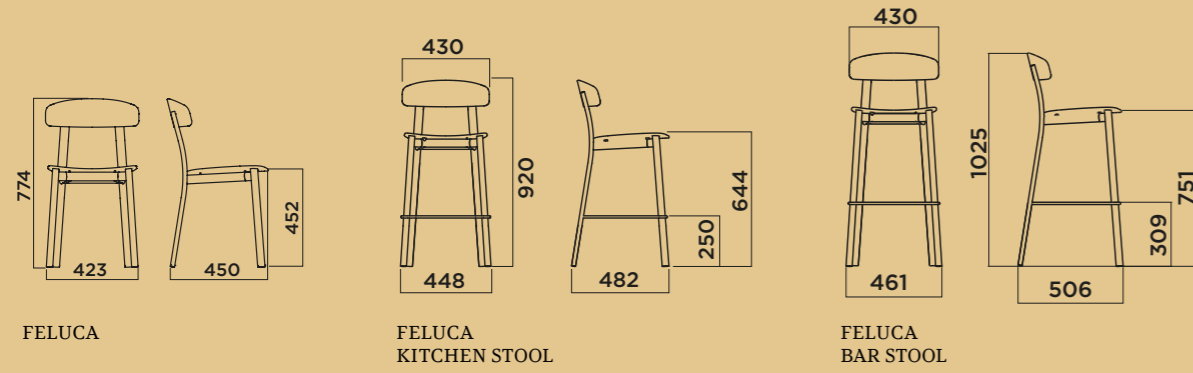

FELUCA

FELUCA
KITCHEN STOOL

FELUCA
BAR STOOL

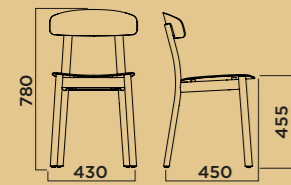

FELUCA ORGANIC

Esempi di combinazioni finiture / Examples of finish combinations:



Reed green/Reed green



Reed green/Reed green



Reed green/Reed green



Reed green/Natural plywood ash



Reed green/Natural plywood ash



Reed green/Natural plywood ash



Natural solid ash/Ochre yellow



Natural solid ash/Ochre yellow



Natural solid ash/Ochre yellow



Ochre yellow/Ochre yellow



Ochre yellow/Ochre yellow



Ochre yellow/Ochre yellow

REMINI- SCENCE



SKOL

[CHAIR]

Design: Needs Studio

IT - C'è qualcosa di familiare in Skol, un'eco di ricordi che affiora nelle sue linee essenziali e senza tempo. La struttura in tubo d'acciaio, sottile ma solida, sorregge con grazia seduta e schienale in multistrato di rovere o, nella versione in polipropilene, perfetta anche per l'outdoor. Morbida nelle forme e rigorosa nei dettagli, unisce influenze retrò e spirito contemporaneo. Con o senza braccioli, si adatta con naturalezza a caffetterie, bistrot, spazi di lavoro e luoghi di incontro.

EN - With its clean, timeless design, something about Skol rekindles memories of simpler times. The slender yet sturdy steel tube frame gracefully supports the seat and backrest in oak plywood or in a polypropylene version, ideal for outdoor use. Featuring soft lines and attention to detail, it combines retro flair with a contemporary soul. With or without armrests, it easily adapts to cafés, bistros, workspaces and meeting places.





[46]



[47]

SKOL

[TECHNICAL DETAILS]

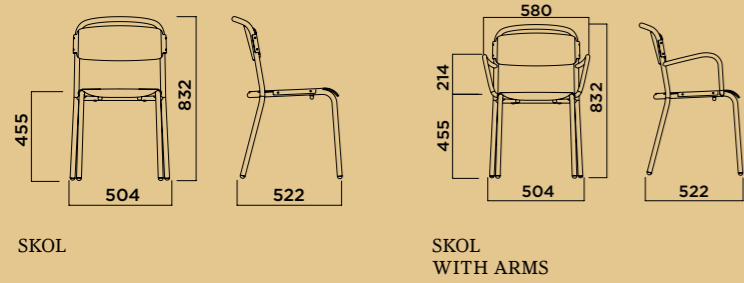

Esempi di combinazioni finiture / Examples of finish combinations:



Ochre yellow/Ochre yellow



Ochre yellow/Natural oak



Ochre yellow/Ochre yellow



Universe blue/Universe blue



Universe blue/Natural oak



Universe blue/Universe blue



Reed green/Reed green



Reed green/Natural oak



Reed green/Reed green



Chromium plated/Coal black



Chromium plated/Natural oak



Chromium plated/Coal black



**CRAFT-
MAN-
SHIP**

TAKUMI

[CHAIR]

Design: Studio Dessì

IT - L'incontro tra industria e artigianato dà vita a Takumi, una collezione che unisce minimalismo e dettagli che rimandano ad epoche passate. I tubi in acciaio si intrecciano come in un'illusione ottica, sostenendo morbide parti imbottite, smontabili e rinnovabili. Con o senza braccioli, questa seduta è perfetta per spazi Horeca e ambienti più intimi, giocando con colori e tessuti per creare combinazioni sofisticate o più audaci.

EN - Industry and craftsmanship come together in Takumi, a collection that incorporates minimalism and details harking back to past eras. The steel tubes intertwine together like in an optical illusion, supporting soft padded elements that can be removed and replaced. With or without armrests, this chair is perfect for both Ho.Re.Ca spaces and more intimate surroundings, combining colours and fabrics to create sophisticated or more daring combinations.





[54]



[55]

TAKUMI

[TECHNICAL DETAILS]

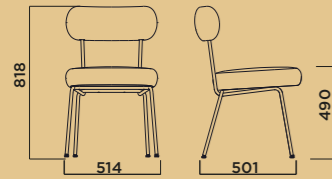

TAKUMI
SIDE CHAIR

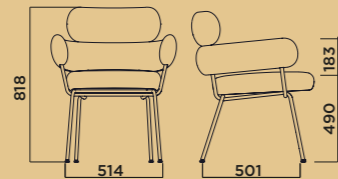

TAKUMI
ARMCHAIR

Esempi di combinazioni finiture / Examples of finish combinations:



Chromium plated/Fiord F0971



Chromium plated/Fiord F0971



Chromium plated/Fiord F0971



Coral red/Convert D CO7614



Coral red/Convert D CO7614



Coral red/Convert D CO7614



Universe blue/Norfolk NF04



Universe blue/Norfolk NF04



Universe blue/Norfolk NF04



Ochre yellow/Volta Celeste VL804



Ochre yellow/Volta Celeste VL804



Ochre yellow/Volta Celeste VL804

TRADI- TION

RUELLE

[CHAIR]

Design: Philippe Tabet

IT - Ruelle racchiude il fascino senza tempo dei bistrot francesi in una seduta leggera e raffinata. Il telaio in alluminio unisce resistenza ed eleganza con un design essenziale. La versione classica ha uno schienale in legno che dona calore, mentre Veranda, pensata per l'outdoor, presenta uno schienale in plastica e fori per il drenaggio. Entrambe possono essere arricchite con un pannello tappezzato, rendendola una scelta versatile per caffè, ristoranti e spazi horeca.

EN - Ruelle captures the timeless charm of French bistros in a lightweight and refined chair. The aluminium frame fuses strength and elegance with a sleek design. The classic version has a wood backrest that imparts a feeling of warmth, while Veranda, designed for outdoor use, has a plastic backrest and small holes for water drainage. Both can be customised with a fabric-covered panel, which makes them a versatile choice for cafés, restaurants and other hospitality venues.





RUELLE

[TECHNICAL DETAILS]

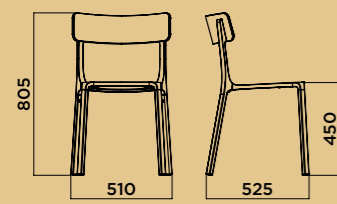

RUELLE

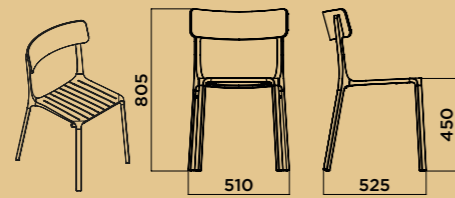

RUELLE
OUTDOOR

Esempi di combinazioni finiture / Examples of finish combinations:



*Aquamarine blue fine textured/
Powder blue*



*Aquamarine blue fine textured/
Powder blue*



*Aquamarine blue fine textured/
Powder blue*



*Light grey fine textured/
Natural plywood oak*



*Light grey fine textured/
Natural plywood oak*



*Light grey fine textured/
Natural plywood oak*



*Lead grey fine textured/
Slate grey*



*Lead grey fine textured/
Slate grey*



*Lead grey fine textured/
Slate grey*



*Embossed white/Natural plywood oak/
Panarea PAN607*



*Embossed white/Natural plywood oak/
Panarea PAN607*



*Embossed white/Natural plywood oak/
Panarea PAN607*

LIGHT- NESS



GT01

[CHAIR]

Design: Gio Tiroto

IT - Leggera, magnetica, perfettamente bilanciata: GT01 è una sedia di puro design, nata per progetti dinamici. Con un peso di soli 3,5 kg, abbina un telaio in alluminio a una seduta ergonomica in multistrato di rovere, entrambi disassemblabili e ripristinabili. Impilabile e facilmente trasportabile grazie all'apposito carrello, è unione ideale tra estetica e funzionalità per ristoranti, coworking e sale conferenze.

EN - A lightweight, irresistible and perfectly balanced chair: GT01 is a masterpiece of design, created for constantly changing projects. Weighing only 3.5 kg, it features an aluminium frame and an ergonomic seat in oak plywood, both of which can be disassembled and re-assembled. Stackable and easily transportable thanks to a trolley for that purpose, it is an ideal combination of aesthetics and functionality for restaurants, co-working and conference rooms.





[70]



[71]

GT01

[TECHNICAL DETAILS]

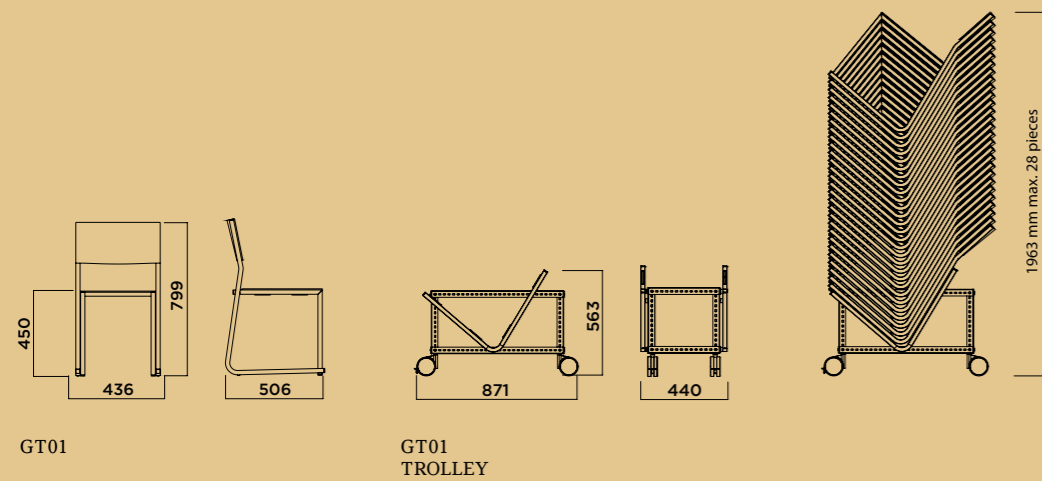

GT01

GT01
TROLLEY

Esempi di combinazioni finiture / Examples of finish combinations:



Brushed aluminium/Natural oak



Brushed aluminium/Natural oak



Brushed aluminium/Natural oak



Oxide red/Black stained oak



Oxide red/Black stained oak



Oxide red/Black stained oak



Dove grey/Natural oak



Dove grey/Natural oak



Dove grey/Natural oak



Oxide red



Dove grey



Black fine textured

ESSEN- TIALITY



[74]

PURE LOOP MONO

[CHAIR]

Design: Claus Breinholt

IT - Pure Loop Mono incarna il design nordico, dove semplicità e funzionalità si incontrano in una forma essenziale. La monoscocca in polipropilene si abbina a diverse basi, adattandosi con naturalezza a ogni contesto, indoor e outdoor. Linee armoniose e materiali versatili la rendono perfetta per spazi lavorativi, hospitality e ambienti domestici.

EN - Pure Loop Mono is the embodiment of Nordic design, where simplicity and functionality merge in clean lines. The polypropylene one-piece shell can be combined with different bases, seamlessly integrating into every setting, both indoors and outdoors. Graceful lines and versatile materials make it ideal for use in office, hospitality and home environments.

[75]



António Champalimaud
Auditorium





PURE LOOP MONO

[TECHNICAL DETAILS]

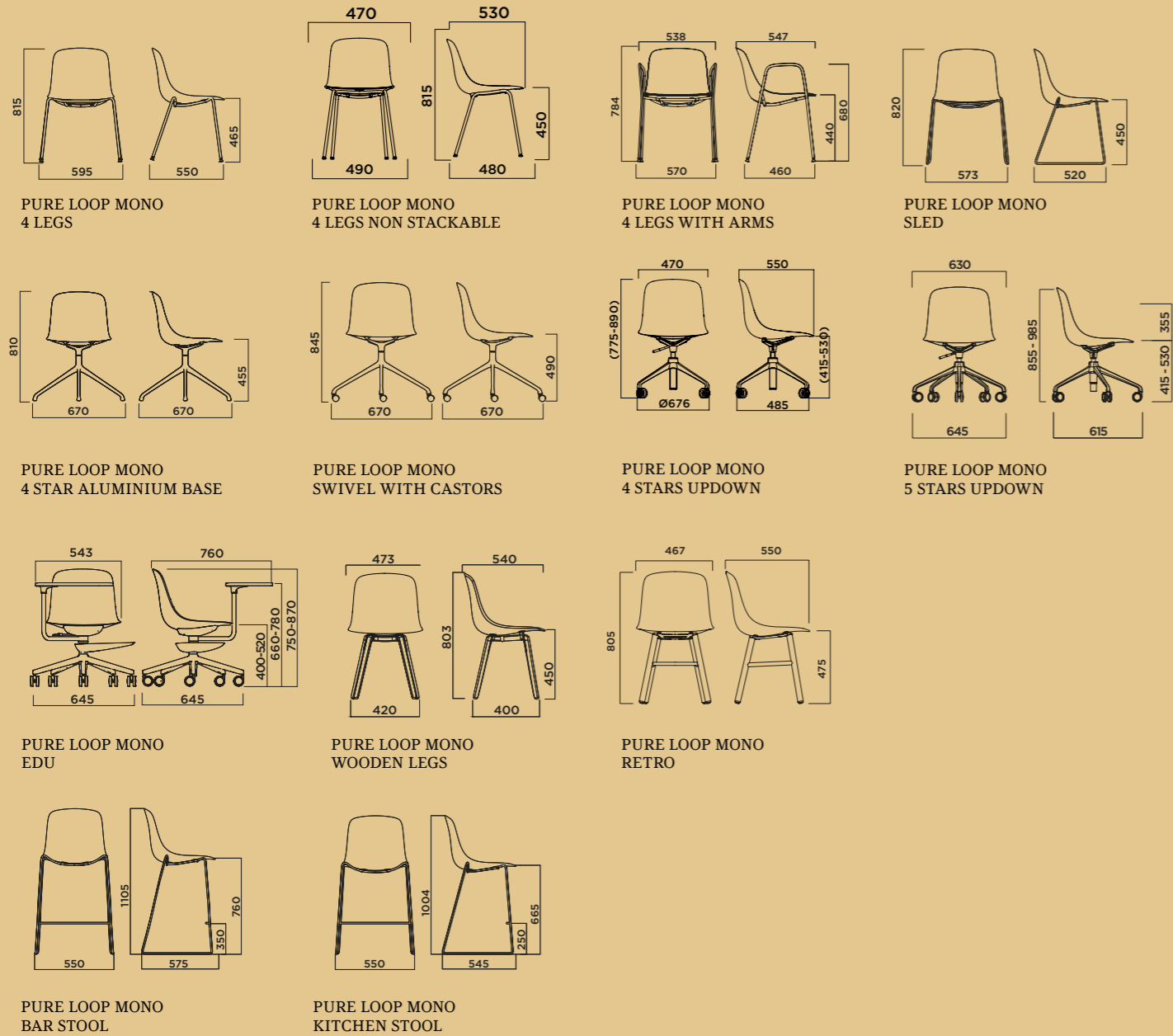

Esempi di combinazioni finiture / Examples of finish combinations:



Matt black/Reed green



Matt black/Reed green



Matt black/Reed green



Powder blue fine textured/Powder blue/ Fiord FO771



Powder blue fine textured/Powder blue/ Fiord FO771



Powder blue fine textured/Powder blue/ Fiord FO771



Oxide Red fine textured/Marsala



Oxide Red fine textured/Marsala



Oxide Red fine textured/Marsala



Matt black/Coal black/Nuvole NV304



Matt black/Coal black/Nuvole NV304



Matt black/Coal black/Nuvole NV304

TIMELESS- SNESS



LOOP MONO [CHAIR]

Design: Claus Breinholt

IT - Loop Mono è un'icona contemporanea, riconoscibile per la sua silhouette armoniosa. La scocca in polipropilene, sottile e leggera, mantiene l'inconfondibile curvatura che ne ha decretato il successo. Braccioli ergonomici e un'ampia scelta di basi e finiture permettono infinite combinazioni, dal tono su tono ai contrasti materici. Un equilibrio perfetto tra comfort, stile e versatilità.

EN - Loop Mono is a contemporary icon, easily recognisable due to its graceful silhouette. The slim, lightweight polypropylene shell retains the unmistakable curves that have made it so popular. Ergonomic armrests and a variety of bases and finishes offer endless combinations, from tone-on-tone options to textural contrasts. Loop Mono is the ideal balance of comfort, style and versatility.

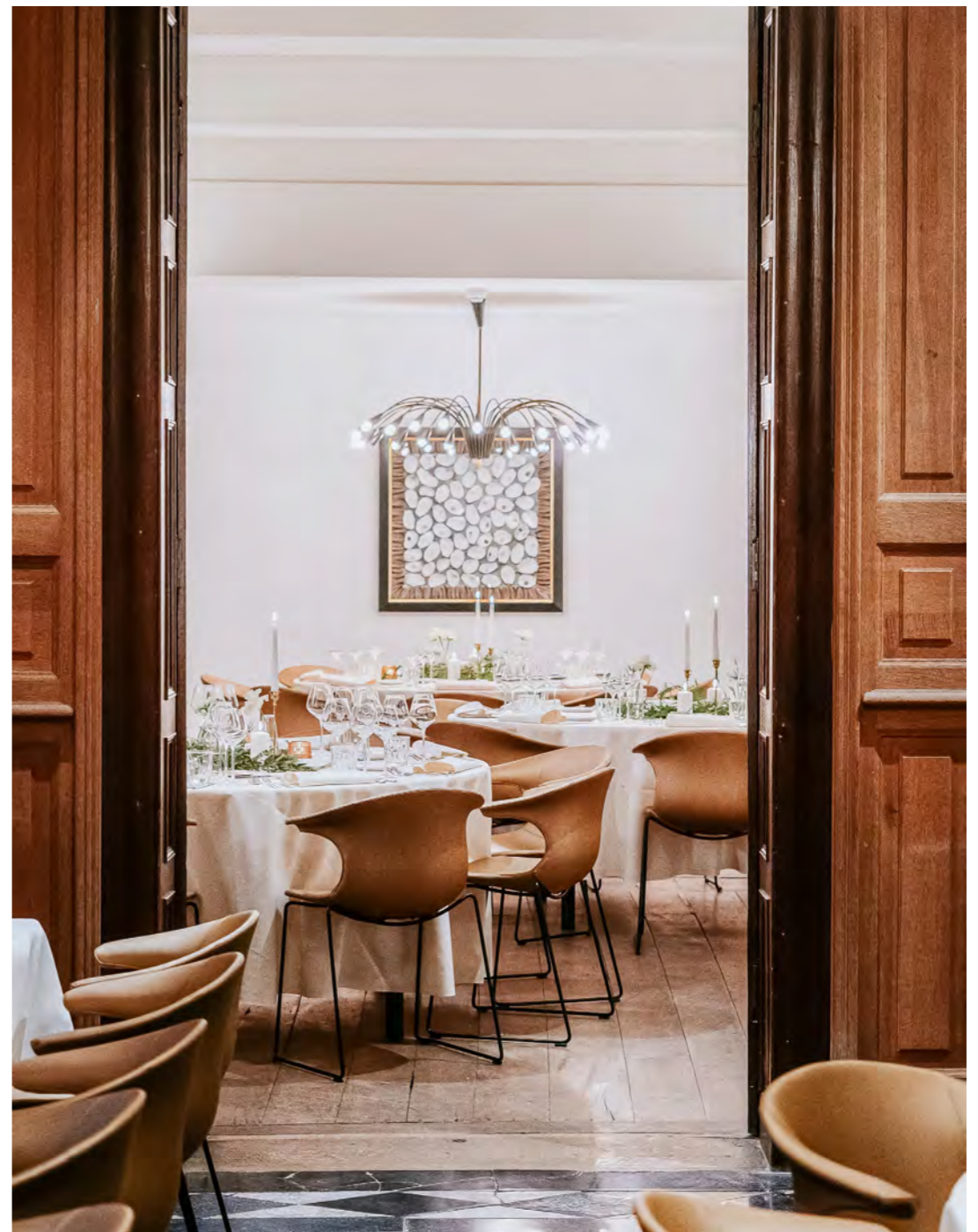



LOOP MONO

[TECHNICAL DETAILS]

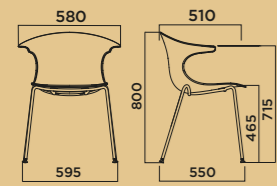

LOOP MONO
4 LEGS

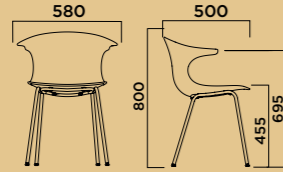

LOOP MONO
4 LEGS NON STACKABLE

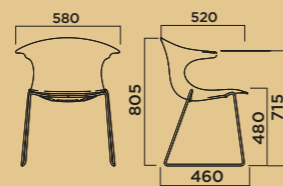

LOOP MONO
SLED

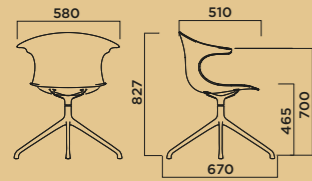

LOOP MONO
4 STAR ALUMINIUM BASE

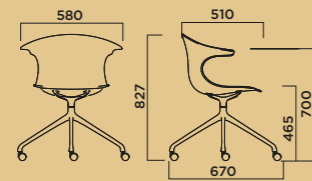

LOOP MONO
SWIVEL WITH CASTORS

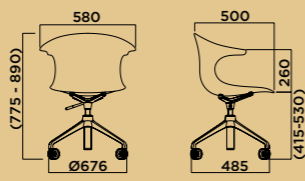

LOOP MONO
4 STARS UPDOWN

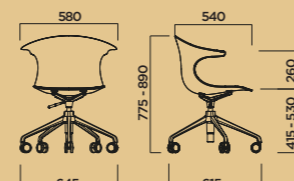

LOOP MONO
5 STARS UPDOWN

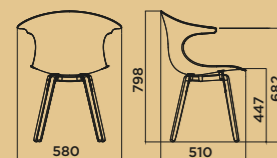

LOOP MONO
WOODEN LEGS

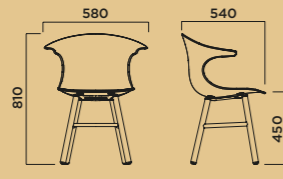

LOOP MONO
RETRO

Esempi di combinazioni finiture / Examples of finish combinations:



Matt black/Marsala



Matt black/Marsala



Matt black/Marsala



Matt black/Powder blue



Matt black/Powder blue



Matt black/Powder blue



Matt black/Coal black



Matt black/Coal black



Matt black/Coal black



Sand fine textured/Sand



Sand fine textured/Sand



Sand fine textured/Sand

ICONI- CITY



LOOP 3D WOOD [CHAIR]

Design: Claus Breinholt

IT - Un'icona senza tempo, la prima scocca monoblocco al mondo con braccioli in legno curvato 3D. Loop 3D Wood è pura armonia: linee fluide e scolpite, levigate come i flutti del mare, danno vita a una seduta dall'eleganza scultorea. Abbinata a un'ampia gamma di basi, arreda con carattere ogni ambiente, rimanendo sempre attuale, sempre riconoscibile.

EN - A timeless icon, this chair is the world's first mono-block body with 3D curved wood armrests. Loop 3D Wood is the essence of harmony: fluid and sculpted lines, smooth as the rolling waves of the sea, bring to life a chair exuding sculptural elegance. Available in a wide range of bases, it brings character to any room, never going out of fashion and always recognisable.





LOOP 3D WOOD

[TECHNICAL DETAILS]

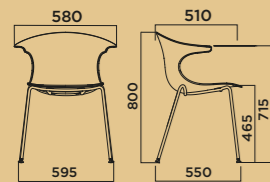

LOOP 3D WOOD
4 LEGS

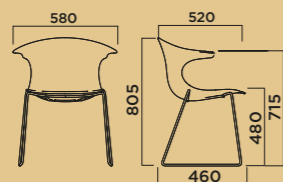

LOOP 3D WOOD
SLED

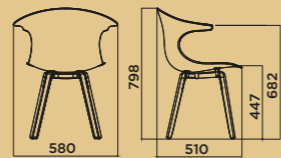

LOOP 3D WOOD
WOODEN LEGS

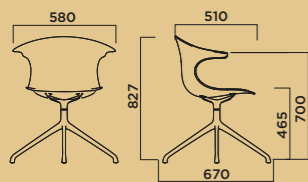

LOOP 3D WOOD
4 STAR ALUMINIUM BASE

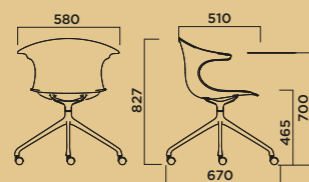

LOOP 3D WOOD
SWIVEL WITH CASTORS

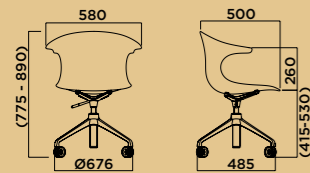

LOOP 3D WOOD
4 STARS UPDOWN

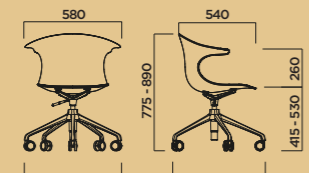

LOOP 3D WOOD
5 STARS UPDOWN

Esempi di combinazioni finiture / Examples of finish combinations:



Matt black/Cherry walnut



Matt black/Cherry walnut



Matt black/Cherry walnut



Black matt/Natural real oak



Black matt/Natural real oak



Black matt/Natural real oak



Black matt/Natural real oak



Black matt/Natural real oak



Black matt/Natural real oak



Chromium plated/Natural real oak



Chromium plated/Natural real oak



Chromium plated/Natural real oak

**PRACTI-
CALITY**



RELIEF

[CHAIR]

Design: Favaretto&Partners

IT - Relief è comfort che prende forma, una monoscocca leggera dal profilo avvolgente. Il rilievo su seduta e schienale ricrea l'effetto di due cuscini virtuali, aggiungendo morbidezza e carattere. Versatile e adattabile, si abbina a diverse basi e trova posto in spazi operativi, ambienti contract e hospitality. Tre versioni di seduta disponibili - in plastica, con seduta imbottita o completamente rivestita - per un perfetto equilibrio tra estetica e funzionalità.

EN - Relief embodies comfort in a lightweight one-piece shell with an enveloping silhouette. The raised surface on the seat and backrest recreates the appearance of two virtual cushions, adding softness and individuality. Versatile and easily adaptable, it can be combined with different bases and fits into workspaces, contract settings and hospitality environments. Three seating versions are available - in plastic, with upholstered seat or fully upholstered - providing the perfect balance between aesthetics and functionality.





RELIEF

[TECHNICAL DETAILS]

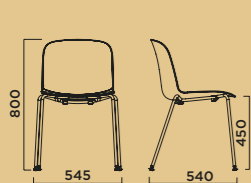

RELIEF
4 LEGS

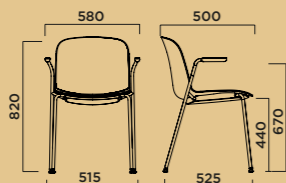

RELIEF
4 LEGS OPEN ARMS

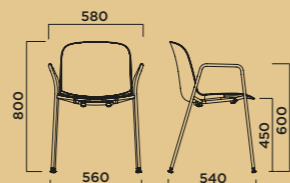

RELIEF
4 LEGS WITH ARMS

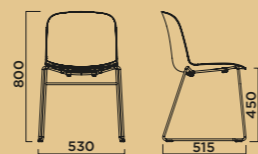

RELIEF
SLED

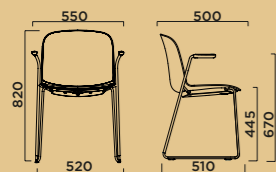

RELIEF
SLED WITH ARMS

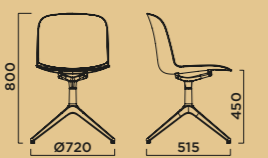

RELIEF
4 STAR ALUMINIUM BASE

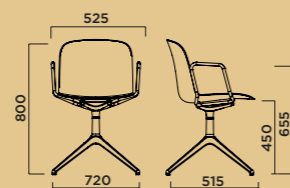

RELIEF
4 STAR ALUMINIUM BASE
WITH ARMS



RELIEF
SWIVEL WITH CASTORS

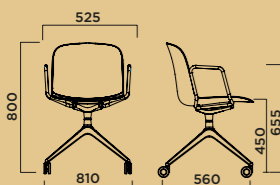

RELIEF
SWIVEL WITH CASTOR
WITH ARMS

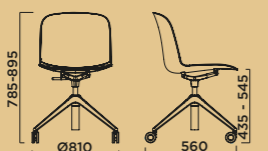

RELIEF 4
STAR UPDOWN

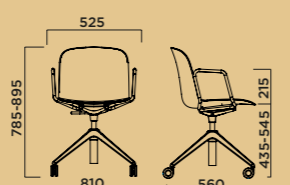

RELIEF 4
STAR UPDOWN WITH ARMS

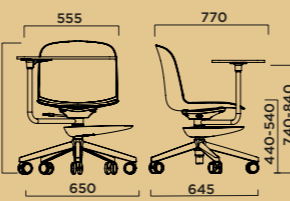

RELIEF
EDU 5 STAR BASE

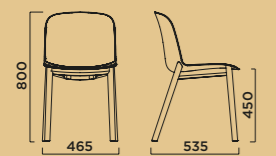

RELIEF
WOODEN LEGS

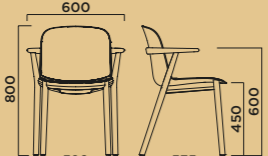

RELIEF
WOODEN LEGS WITH ARMS

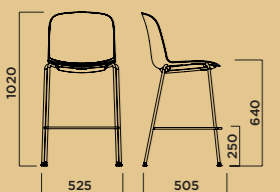

RELIEF
4 LEGS KITCHEN STOOL

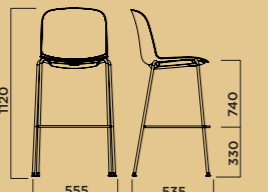

RELIEF
4 LEGS BAR STOOL



RELIEF
SLED KITCHEN STOOL

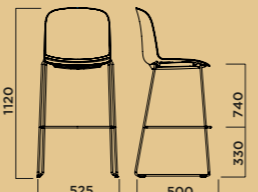

RELIEF
SLED BAR STOOL

Esempi di combinazioni finiture / Examples of finish combinations:



Matt black/Coal black



Matt black/Coal black



Matt black/Coal black



Matt black/Universe blue



Matt black/Universe blue



Coral red/Universe blue



Reed green/Reed green



Reed green/Reed green



Reed green/Reed green



*Matt black/coal black/
Steelcut Quartet SQ144*



*Matt black/coal black/
Steelcut Quartet SQ144*



*Matt black/coal black/
Steelcut Quartet SQ144*

ENVE- LOPMENT



[106]

SICLA

[CHAIR]

Design: Claus Breinholt

IT - Sicla è leggerezza che avvolge, una seduta solida ma visivamente fluida. La monoscocca in polipropilene, sostenuta da una nervatura posteriore, unisce stabilità e dinamismo. Con un'ampia scelta di basi, si adatta con naturalezza a ogni contesto. Il sedile, imbottito o con pannello morbido, aggiunge comfort, mentre le finiture giocano con la luce per esaltarne i dettagli.

EN - Sicla represents embracing lightness in a solid yet visually sinuous chair. The polypropylene one-piece shell, supported by a rib on the back, fuses stability with dynamic performance. Featuring a wide choice of bases, it adapts effortlessly to any scenario. The chair, padded or with a cushioned panel, adds comfort, while light reflects off the surface finishes to accentuate the details.

[107]





[110]



[111]

SICLA

[TECHNICAL DETAILS]

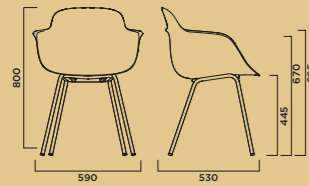

SICLA
4 LEGS

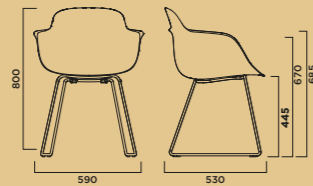

SICLA
SLED

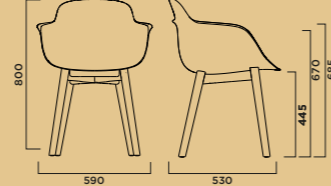

SICLA
WOODEN LEGS

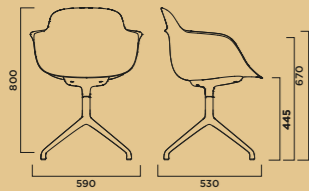

SICLA
4 STAR ALUMINIUM BASE

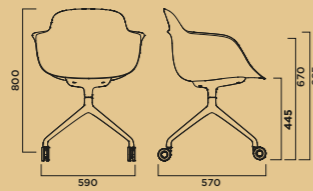

SICLA
SWIVEL WITH CASTORS

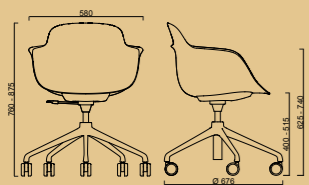

SICLA
5 STARS UPDOWN

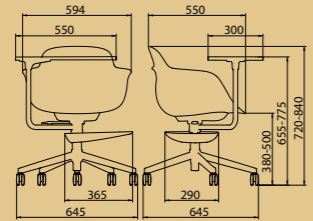

SICLA
EDU

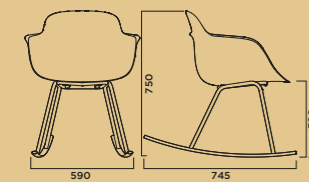

SICLA
ROCKING

Esempi di combinazioni finiture / Examples of finish combinations:



Oxide red fine textured/Marsala



Oxide red fine textured/Marsala



Oxide red fine textured/Marsala



Sand fine textured/Sand



Sand fine textured/Sand



Sand fine textured/Sand



*Matt black/Marsala/
Convert D CO7558*



*Matt black/Marsala/
Convert D CO7558*



*Matt black/Marsala/
Convert D CO7558*



Sand fine textured/Sand/Nuvole NV900



Sand fine textured/Sand/Nuvole NV900



Sand fine textured/Sand/Nuvole NV900

BA- LANCCE



HARMO

[CHAIR]

Design: BrogliatoTraverso

IT - Harmo è un equilibrio perfetto tra forma e materia, dove il legno incontra linee essenziali e dettagli raffinati. L'iconico aggancio dello schienale ne esalta il carattere, donando leggerezza alla struttura. Realizzata in faggio o frassino, è disponibile in sedia, sgabello e poltroncina lounge Relax. Sedile e schienale possono essere lasciati a vista o rivestiti per un comfort su misura.

EN - Harmo seamlessly balances form and material, where wood embraces clean lines and refined details. The iconic backrest fitting accentuates its design, endowing the structure with a sense of lightness. Made of beech or ash, it is available in chair, stool and Relax lounge chair versions. Seat and backrest can be made with or without upholstery for bespoke comfort.







[120]



[121]

HARMO

[TECHNICAL DETAILS]

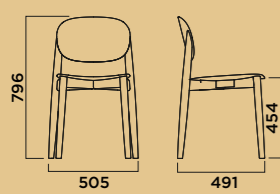

HARMO

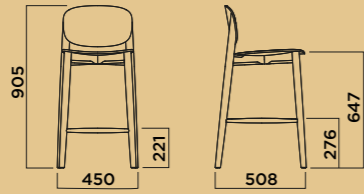

HARMO
KITCHEN STOOL

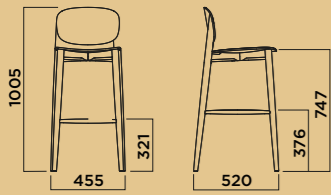

HARMO
BAR STOOL

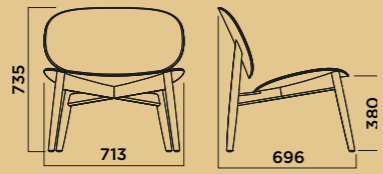

HARMO
LOUNGE

Esempi di combinazioni finiture / Examples of finish combinations:



Natural solid ash



Natural solid ash



Natural solid ash



Basalt grey stained solid ash



Basalt grey stained solid ash



Basalt grey stained solid ash



Blue grey stained solid ash



Blue grey stained solid ash



Blue grey stained solid ash



Black stained solid ash/Nuvole NV404



Black stained solid ash/Nuvole NV404



Black stained solid ash/Nuvole NV404

SOPHI-
STICA-
TION



[124]

SEAME

[CHAIR]

Design: Klaus Nolting

IT - Seame è un connubio di leggerezza e solidità, un pezzo che sembra scolpito da un unico blocco di legno. Le venature sottili ne esaltano la sinuosità, mentre i bordi bombati e in rilievo ne definiscono la forma con armonia. Disponibile anche con braccioli, la struttura conferisce stile e praticità: senza intaccarne il fascino senza tempo.

EN - Seame combines lightness and sturdiness, giving the impression of being carved from a single block of wood. The subtle veined pattern of the wood accentuates its sinuous shape, while the rounded and raised edges complete the design to perfection. Also available with armrests, the chair's structure is both stylish and practical, without detracting from its timeless charm.

[125]





[128]



[129]

SEAME

[TECHNICAL DETAILS]

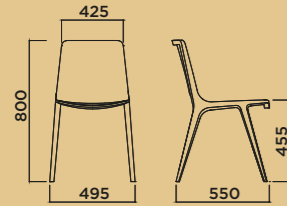

SEAME
CHAIR

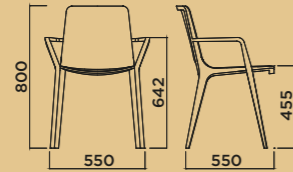

SEAME
ARMCHAIR

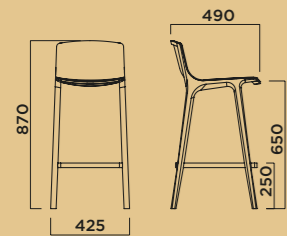

SEAME
KITCHEN STOOL

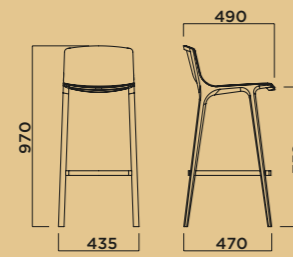

SEAME
BAR STOOL

Esempi di combinazioni finiture / Examples of finish combinations:



Natural solid oak



Natural solid oak



Natural solid oak



Black stained oak



Black stained oak



Black stained oak



Natural solid oak



Natural solid oak



Natural solid oak



Black stained oak



Black stained oak



Black stained oak

PURI- TY



WOOD STOCK

[CHAIR]

Design: Kai Stania

IT - Woodstock celebra la purezza del legno con linee morbide e un design leggero, ma solido. Realizzata in multistrato di rovere, è pensata per essere impilata con facilità, mantenendo un profilo unico. Il linking device opzionale permette di unirla in file compatte, trasformandola nella soluzione perfetta per spazi condivisi e sale conferenze. Naturale, versatile e funzionale, Woodstock porta calore e armonia in ogni ambiente.

EN - Woodstock glorifies the purity of wood with soft lines and a light yet solid design. Made of oak plywood, it is designed to be easily stacked, while preserving its unique shape. The optional linking attachment makes it possible to combine them into compact rows, making it the perfect solution for communal spaces and conference rooms. With its natural, versatile and functional appearance, Woodstock creates a warm and harmonious vibe in any environment.





[136]



[137]

WOODSTOCK

[TECHNICAL DETAILS]

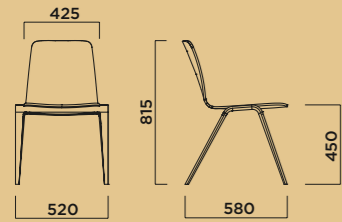

WOODSTOCK
CHAIR

Esempi di combinazioni finiture / Examples of finish combinations:



Natural oak



Natural oak



Natural oak



Black stained oak



Black stained oak



Black stained oak



Basalt grey oak



Basalt grey oak



Basalt grey oak



Natural oak/Hero Heather HH0463



Natural oak/Hero Heather HH0463



Natural oak/Hero Heather HH0463

FRESH- NESS



[140]

PORTA VENEZIA

[CHAIR]

Design: Dorigo Design

IT - Porta Venezia è una sintesi che unisce materiali diversi in un dialogo armonioso tra tradizione e modernità. Sedie e sgabelli dal design fresco e vivace, valorizzati da una gamma di colori e finiture che li rendono perfetti per bar, caffetterie e spazi conviviali. Con la sua spontaneità e il suo carattere distintivo, porta sempre un tocco di stile.

EN - Porta Venezia brings together different materials resulting in a harmonious fusion of tradition and modernity. Chairs and stools offering a fresh and dynamic design are available in a range of hues and finishes that make them the perfect choice for bars, cafés and other social spaces. Characterised by an air of spontaneity and originality, it always succeeds with adding a dash of style.

[141]





[144]



[145]

PORTA VENEZIA

[TECHNICAL DETAILS]

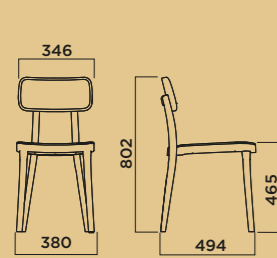

PORTA VENEZIA
CHAIR

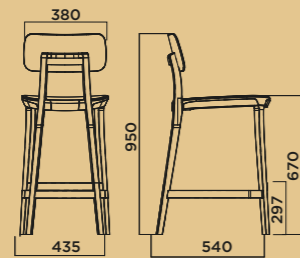

PORTA VENEZIA
KITCHEN STOOL

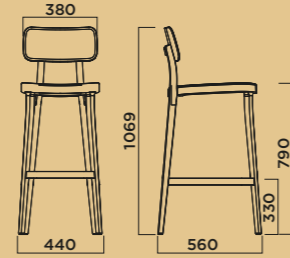

PORTA VENEZIA
BAR STOOL

Esempi di combinazioni finiture / Examples of finish combinations:



Natural solid beech/Military green



Natural solid beech/Military green



Natural solid beech/Military green



Black stained solid beech/Tobacco



Black stained solid beech/Tobacco



Black stained solid beech/Tobacco



Natural solid beech/Black



Natural solid beech/Black



Natural solid beech/Black



Black stained oak/Pearl grey



Black stained oak/Pearl grey



Black stained oak/Pearl grey

HAR- MONY



SETTE SUSETTE [CHAIR]

Design: BrogliatoTraverso

IT - Settesusette nasce dall'incontro tra materiali opposti che si armonizzano con naturalezza: il calore del legno e la modernità del polipropilene si fondono in una struttura continua ed elegante. Il design pulito rivela il suo carattere nel retro, dove l'unione dei materiali diventa un segno distintivo. Versatile e raffinata, si inserisce con disinvoltura in spazi domestici e contract, valorizzando ogni ambiente con combinazioni cromatiche sofisticate.

EN - Settesusette originated from effortlessly merging different materials: the warmth of wood and the modernity of polypropylene fuse together creating a fluid and elegant product. The sleek design has a distinctive retro feature on the back, where the combination of materials gives it a unique look. Both versatile and stylish, it fits easily into both domestic and contract environments, embellishing any space with sophisticated colour combinations.





[152]



[153]

SETTESUSETTE

[TECHNICAL DETAILS]

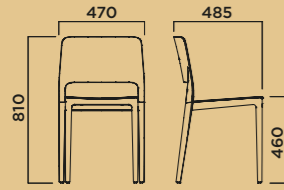

SETTESUSETTE
CHAIR

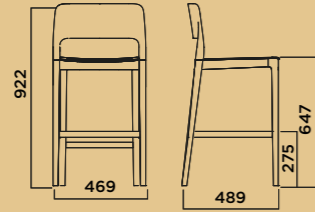

SETTESUSETTE
KITCHEN STOOL

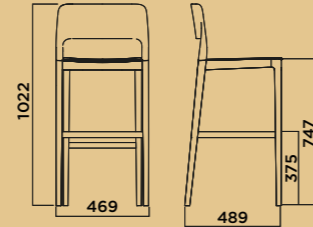

SETTESUSETTE
BAR STOOL

Esempi di combinazioni finiture / Examples of finish combinations:



Natural solid beech/Almond grey



Natural solid beech/Almond grey



Natural solid beech/Almond grey



Natural Solid beech/Light grey



Natural Solid beech/Light grey



Natural Solid beech/Light grey



Natural solid beech/White



Natural solid beech/White



Natural solid beech/White



Natural solid beech/White



Natural solid beech/White



Natural solid beech/White

MOVE- MENT



[156]

ROUND & ROUND [STOOL]

Design: Oleg Pugachev

IT - Round&Round unisce purezza delle forme e funzionalità con dettagli sorprendenti. La seduta, in plastica o legno, è disponibile anche imbottita per un comfort maggiore. Nella versione girevole, un meccanismo invisibile aggiunge dinamicità senza alterare l'armonia. La struttura in acciaio verniciato, sottile ma solida, completa un complemento raffinato e versatile, perfetto per qualsiasi spazio.

EN - Round&Round fuses pure lines and functionality with striking details. The plastic or wood seat is also available with cushioning for greater comfort. The swivel version has an invisible mechanism that allows it to rotate without altering its graceful appearance. The slender albeit solid painted steel structure forms a refined and versatile item of furniture, ideal for any space.

[157]





[160]



[161]

ROUND & ROUND

[TECHNICAL DETAILS]

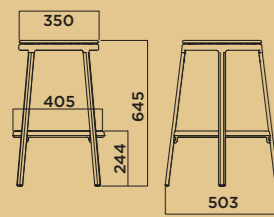

ROUND & ROUND
KITCHEN STOOL

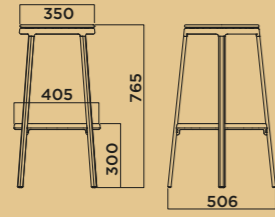

ROUND & ROUND
BAR STOOL

Esempi di combinazioni finiture / Examples of finish combinations:



*Powder blue fine textured/
powder blue*



*Powder blue fine textured/
Natural ash*



*Powder blue fine textured/
Nuvole NV704*



Embossed white/white



Embossed white/ natural ash



Embossed white/ Norfolk NF06



Ochre yellow/ochre yellow



Ochre yellow/Black stained ash



*Ochre yellow/
Steelcut Quartet SQ414*



Coral red/ coral red



Coral red/ black stained ash



Coral red/ Oceanic OC12

DYNA- MISM



[164]

ROUND & ROLL [STOOL]

Design: Oleg Pugachev

IT - Round&Roll è uno sgabello compatto e versatile, progettato per accompagnare il movimento. Colorato e leggero, si sposta con facilità ed è perfetto per ambienti di lavoro e spazi educational. La seduta, disponibile fissa o girevole, poggia su una struttura solida che integra una pratica basket base portaoggetti. Grazie alle dimensioni contenute, si ripone facilmente, pronto a essere usato quando serve.

EN - Round&Roll is a compact and versatile stool, specifically designed to be moved around. Brightly coloured and lightweight, it is easy to manoeuvre making it perfect for workplaces and classrooms. The seat, in either a fixed or swivel version, rests on a sturdy frame that includes a convenient storage "basket" at its base. Its compact size means it can be easily stored, ready to be used when needed.

[165]

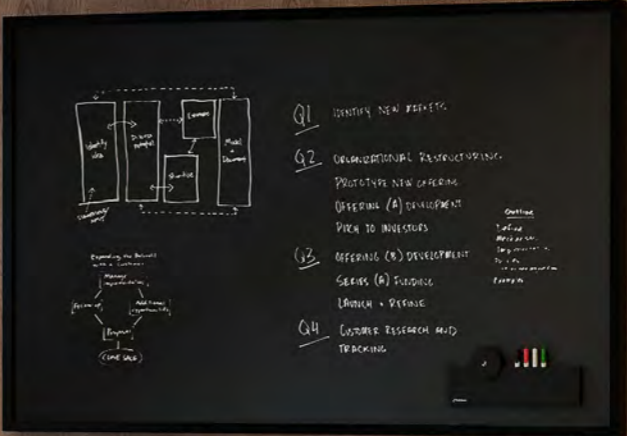

Q1 IDENTIFY NEW ASPECTS
Q2 DEVELOPMENTAL RESTRUCTURING
PROTOTYPE NEW OFFERINGS
PITCH TO INVESTORS
Q3 OFFERING (A) DEVELOPMENT
SERIES (A) FUNDING
LAUNCH + REFINE
Q4 CUSTOMER RESEARCH AND TRACKING



[168]



[169]

ROUND & ROLL

[TECHNICAL DETAILS]

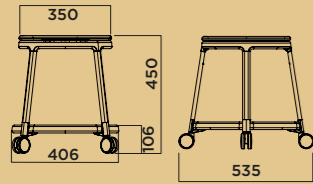

ROUND & ROLL

Esempi di combinazioni finiture / Examples of finish combinations:



Coral red/Coral red



Coral red/Natural ash



Coral red/Fiord FO581



Reed green/Reed green



Reed green/Black stained ash



Reed green/Steelcut Quartet SQ0924



Powder blue/Powder blue



Powder blue/Natural ash



Powder blue/Convert D CO7361



Embossed anthracite/Anthracite



Embossed anthracite/Black stained ash



*Embossed anthracite/
Step Melange SM60004*

INTUITION



[172]

FLIP

[STOOL]

Design: BrogliatoTraverso

[2024]

IT - Un segno leggero, come tracciato a matita, disegna la struttura di Flip: un tubo d'acciaio che si avvolge con disinvoltura attorno al traverso, sorreggendo una seduta ergonomica e delicata. In polipropilene o tappezzata per un comfort ancora maggiore, gioca con abbinamenti tono su tono o a contrasto. Versatile e raffinato, questo sgabello trova posto in caffè, ristoranti, uffici e spazi pubblici.

EN - A subtle pencil-like line traces the structure of Flip: a steel tube that wraps effortlessly around the crosspiece, supporting an ergonomic and delicately-shaped seat. Available in polypropylene or upholstered for even greater comfort, it can be combined in tone-on-tone or contrasting colours. Versatile and elegant, this stool adapts to cafés, restaurants, offices and public spaces.

[173]





[176]



[177]

FLIP

[TECHNICAL DETAILS]

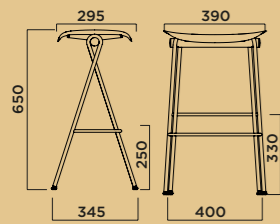

FLIP
KITCHEN STOOL

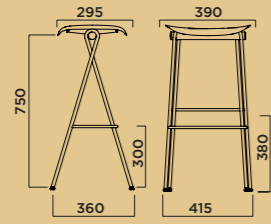

FLIP
BAR STOOL

Esempi di combinazioni finiture / Examples of finish combinations:



Reed green/Coal black



Reed green/Reed green



Black fine textured/Reed green



Universe blue/Coal black



Universe blue/Universe blue



Black fine textured/Universe blue



Antique brass/Coal black



Antique brass/Reed green



Antique brass/Universe blue



Coral red/Coal black



Coral red/Coral red



Black fine textured/Coral red

SIMPLI-CITY



[180]

KLEJN

[STOOL]

Design: Thomas Pedersen

IT - Klejn è uno sgabello leggero e versatile, ispirato alle strutture industriali reinterpretate con stile. La silhouette in tondino d'acciaio, sottile ma solida, accoglie una seduta in plastica o legno, anche nella versione tappezzata per un comfort maggiore. Disponibile in tre altezze e diverse finiture, si abbina con disinvoltura a qualsiasi ambiente, aggiungendo colore o un tocco raffinato. Pratico e maneggevole, si sposta con facilità, adattandosi a ogni necessità.

EN - Inspired by industrial structures, Klejn is a lightweight and versatile stool with a stylish twist. The frame, made of thin but solid steel rods, supports a plastic or wood seat, available also in a padded version for greater comfort. Available in three heights and different finishes, it blends in effortlessly with any environment, adding colour or a touch of refinement. Practical and easy to handle, it can be repositioned with ease, adapting to every need.

[181]



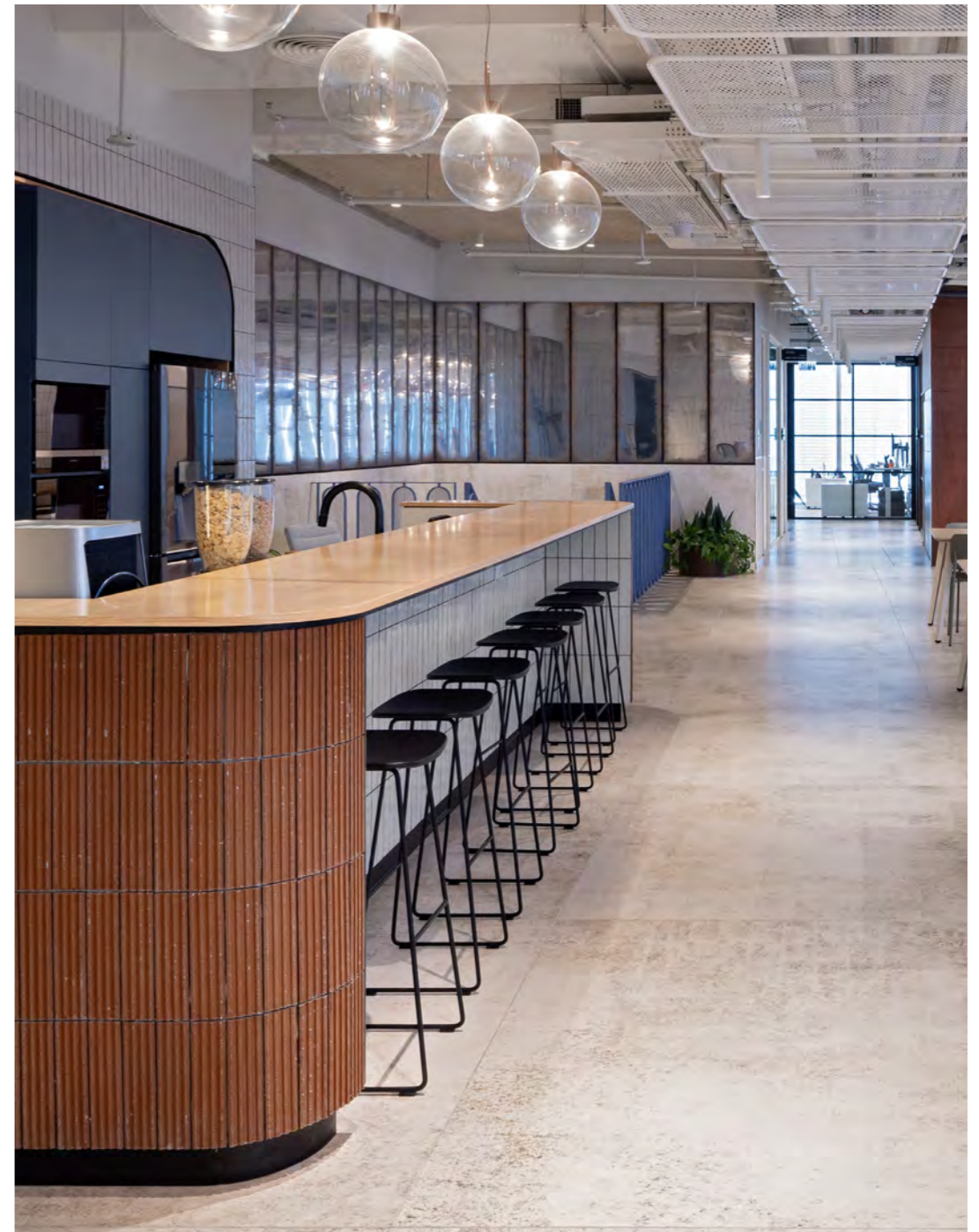



[186]



[187]

KLEJN

[TECHNICAL DETAILS]

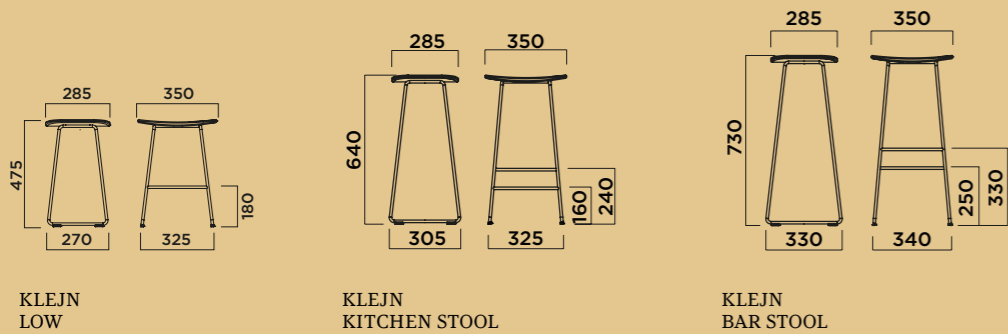

Esempi di combinazioni finiture / Examples of finish combinations:



Matt white/Natural ash



Matt white/Natural ash



Matt white/Natural ash



Matt black/Powder blue



Matt black/Powder blue



Matt black/Powder blue



*Matt black/Black stained ash/
Convert D CO7360*



*Matt black/Black stained ash/
Convert D CO7360*

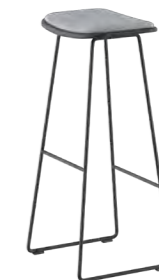

*Matt black/Black stained ash/
Convert D CO7360*



*Matt white/white/
SQ224 Steelcut Quartet*



*Matt white/white/
SQ224 Steelcut Quartet*



*Matt white/white/
SQ224 Steelcut Quartet*

SMOOTHNESS



FLINK

[STOOL]

Design: Thomas Pedersen

IT - Flink si ispira ai ciottoli levigati dal tempo, con forme morbide che invitano al comfort. La base rotonda in acciaio e il supporto in alluminio garantiscono stabilità, mentre la seduta, in legno o rivestita in tessuto, dà calore allo spazio. Nella versione alta, il poggiatesta offre un supporto discreto ma essenziale, mentre la variante Low, più compatta, è una soluzione intelligente per ottimizzare lo spazio.

EN - The inspiration for Flink can be found in pebbles smoothed by the passage of time resulting in the gently rounded shapes designed for comfort. The round steel base and aluminium support give it stability, while the wood or fabric seat helps to create a warm environment. For the kitchen and bar stool versions, the footrest discretely but effectively provides support, while the more compact low stool version offers a clever space-saving solution.





[194]



[195]

FLINK

[TECHNICAL DETAILS]

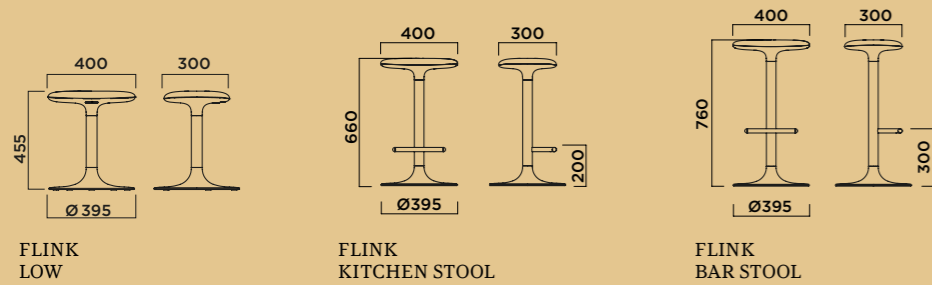

FLINK
LOW

FLINK
KITCHEN STOOL

FLINK
BAR STOOL

Esempi di combinazioni finiture / Examples of finish combinations:



Light grey textured/Natural ash



Light grey textured/Natural ash



Light grey textured/Natural ash



*Lead grey fine textured/
Norfolk NF09*



*Lead grey fine textured/
Norfolk NF09*



*Lead grey fine textured/
Norfolk NF09*



Dove grey fine textured/Natural ash



Dove grey fine textured/Natural ash



Dove grey fine textured/Natural ash



White embossed/Fiord FO271



White embossed/Fiord FO271



White embossed/Fiord FO271

COM-
PACT-
NESS



[198]

**PURE
LOOP MINI**
[STOOL]

Design: Claus Breinholt

IT - Pure Loop Mini combina proporzioni compatte e forme avvolgenti in una scocca in polipropilene che si abbina a una varietà di basi e telai. Perfetto per interni ed esterni, si inserisce con disinvoltura in ogni contesto, offrendo soluzioni dinamiche e dal notevole impatto visivo. È uno sgabello che si pone come elemento distintivo pratico e dalla personalità spiccata.

EN - Pure Loop Mini features compact proportions and a curvaceous design in a polypropylene shell that can be combined with a variety of bases and frames. Perfect for indoors and outdoors, it blends in easily into any setting, offering striking and flexible solutions. In other words, a stool characterised by its practicality and originality.

[199]





PURE LOOP MINI

[TECHNICAL DETAILS]

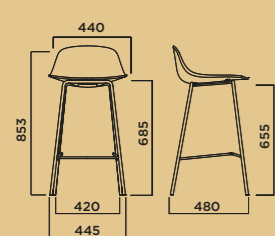

PURE LOOP MINI
4 LEGS KITCHEN

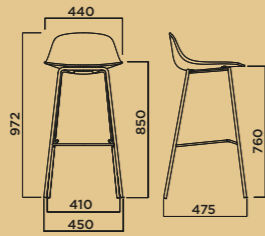

PURE LOOP MINI
4 LEGS BAR

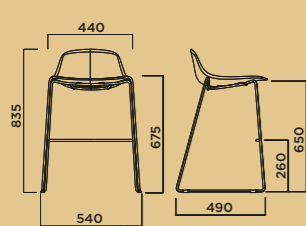

PURE LOOP MINI
ROD KITCHEN

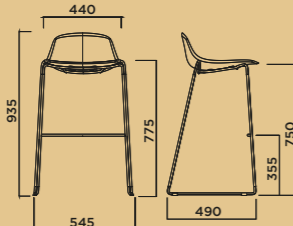

PURE LOOP MINI
ROD BAR

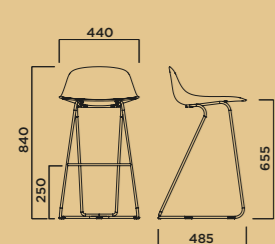

PURE LOOP MINI
DANDY KITCHEN

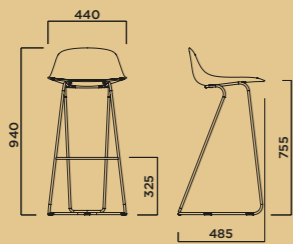

PURE LOOP MINI
DANDY BAR

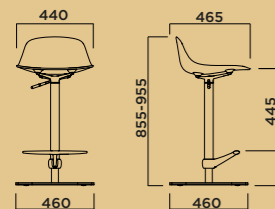

PURE LOOP MINI
UPDOWN

Esempi di combinazioni finiture / Examples of finish combinations:



Matt black/Powder blue



Matt black/Powder blue



Matt black/Powder blue



Matt black/Sand



Matt black/Sand



Matt black/Sand



Powder blue fine textured/Powder blue



Powder blue fine textured/Powder blue



Powder blue fine textured/Powder blue



Matt black/Natural 3D Plywood



Matt black/Natural 3D Plywood



Matt black/Natural 3D Plywood

LOUNGE & SOFA



SOFT- NESS

BOMBOM

[ARMCHAIR]

Design: Favaretto&Partners

IT - BomBom è una poltrona che accoglie con forme soffici e avvolgenti, in un abbraccio di pura morbidezza. Il rivestimento può giocare su due colori diversi tra interno ed esterno, esaltandone l'unicità. Disponibile con telaio a quattro gambe o base girevole a quattro razze, trasforma il momento di attesa in un comfort senza eguali.

EN - BomBom is an armchair that envelops you with its soft, cosy shapes, in an embrace of pure softness. Its upholstery can alternate two different colours, on its interior and exterior, making it even more unique. Available with a four-leg frame or a four-spoke swivel base, this chair transforms downtime into unprecedented comfort.





[212]



[213]

BOMBOM

[TECHNICAL DETAILS]

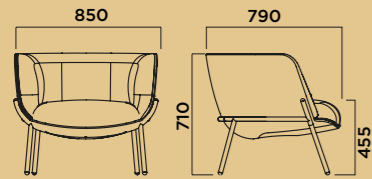

BOM BOM
4 LEGS

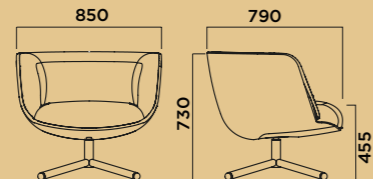

BOM BOM
4 STARS

Esempi di combinazioni finiture / Examples of finish combinations:



*Dove grey fine textured/
FIORD out FO451 in FO271*



*Dove grey fine textured/
FIORD out FO451 in FO271*



*Dove grey fine textured/
FIORD out FO451 in FO271*



*Oxide red fine textured/
Convert D CO7211*



*Oxide red fine textured/
Convert D CO7211*



*Oxide red fine textured/
Convert D CO7211*



*Dove grey fine textured/
Guest out GU0760 in GU0140*



*Dove grey fine textured/
Guest out GU0760 in GU0140*



*Dove grey fine textured/
Guest out GU0760 in GU0140*

COM- FORT



[216]

PEB

[ARMCHAIR]

Design: BrogliatoTraverso

IT - La silhouette di Peb è un intreccio di forme tondeggianti e proporzioni generose, che si integrano con gambe in legno o struttura in metallo; disponibile con schienale basso o alto, questa poltroncina si presta ad essere tappezzata con un'ampia gamma di rivestimenti. Nella versione Modesty Panel, le ali laterali offrono una dimensione di privacy e protezione, perfetta per uffici, coworking e lounge.

EN - A combination of rounded shapes and generous proportions, Peb's design features wood legs or a metal frame. Available with a low or high backrest, this armchair can be upholstered in a wide range of fabrics. The Modesty Panel version with side wings offers privacy and protection, perfect for offices, co-working spaces and lounges.

[217]

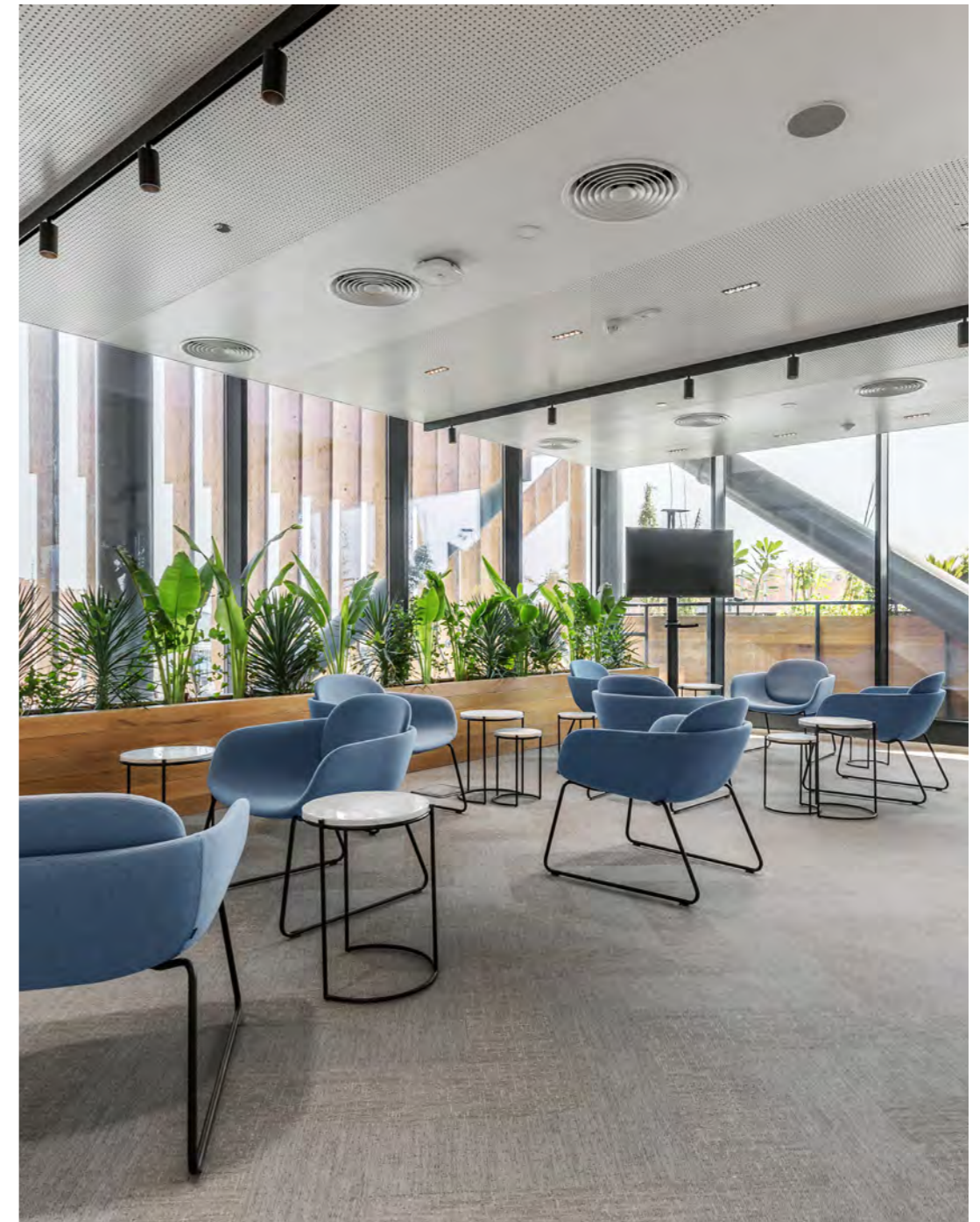



[220]



[221]

PEB

[TECHNICAL DETAILS]

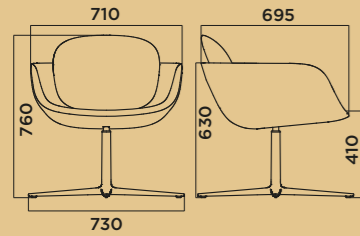

PEB 4 STARS
LOW BACK

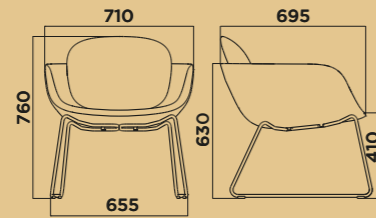

PEB SLED
LOW BACK

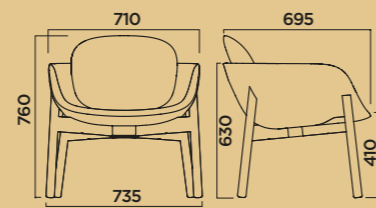

PEB WOODEN LEGS
LOW BACK

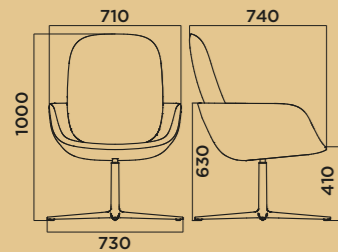

PEB 4 STARS
HIGH BACK

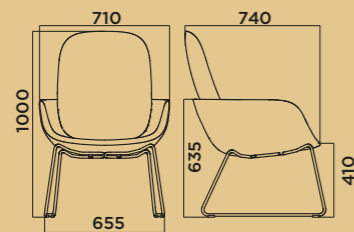

PEB SLED
HIGH BACK

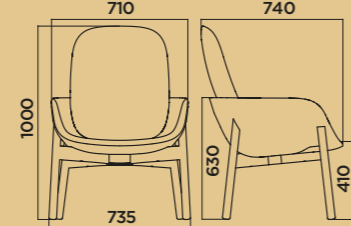

PEB WOODEN LEGS
HIGH BACK

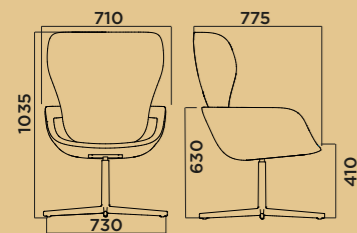

PEB 4 STARS
MODESTY PANEL

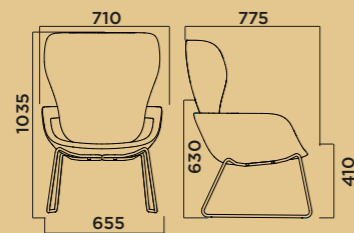

PEB SLED
MODESTY PANEL

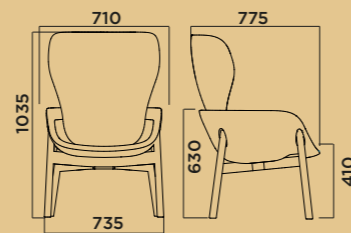

PEB WOODEN LEGS
MODESTY PANEL

Esempi di combinazioni finiture / Examples of finish combinations:



*Dove grey fine textured/
Guest seat GU0250 back GU0270*



*Dove grey fine textured/
Guest seat GU0250 back GU0270*



*Dove grey fine textured/
Guest seat GU0250 back GU0270*



*Black stained solid ash/
Hero Heather seat HH0753 back HH0713*



*Black stained solid ash/
Hero Heather seat HH0753 back HH0713*



*Black stained solid ash/
Hero Heather seat HH0753 back HH0713*



*Oxide red fine textured/
Hero 2 seat HE0372 back HE0312*



*Oxide red fine textured/
Hero 2 seat HE0372 back HE0312*



*Oxide red fine textured/
Hero 2 seat HE0372 back HE0312*

SCULP- TURALI- TY



[224]

KRAM

[LOUNGE CHAIR]

Design: Thomas Pedersen

IT - Kram è un'icona di eleganza scultorea, una poltrona lounge che cattura lo sguardo con le sue curve avvolgenti ispirate a una conchiglia aperta. La struttura a tre gambe in acciaio esalta il calore del legno venato, creando un equilibrio tra leggerezza e presenza scenica. Disponibile anche imbottita, trasforma ogni sala d'attesa o lobby in uno spazio di puro design.

EN - Kram is an iconic example of sculptural elegance: a lounge chair that catches the eye with its enveloping curves inspired by an open seashell. The three-legged steel frame sets off the natural warmth of the veined wood, creating a balance between lightness and visual impact. Also available upholstered, it transforms any waiting room or lobby into an area of pure design.

[225]





KRAM

[TECHNICAL DETAILS]

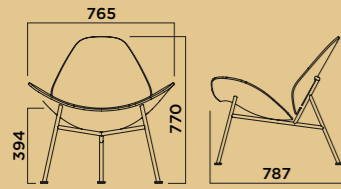

KRAM

Esempi di combinazioni finiture / Examples of finish combinations:



Matt black/Black stained real oak



Matt black/Black stained real oak



Matt black/Black stained real oak



Chromium plated/Natural real oak



Chromium plated/Natural real oak



Chromium plated/Natural real oak



*Antique brass/American walnut/
Nuvole NV405*



*Antique brass/American walnut/
Nuvole NV405*



*Antique brass/American walnut/
Nuvole NV405*

TRAN- SFORMA- TION



[232]

SYS [MODULAR SOFA] Design: mc.Dsg

IT - Sys è un divano modulare, pensato per adattarsi a spazi in continua evoluzione. La struttura in acciaio verniciato da 2, 3 e 4 posti accoglie vari tipi di sedute e tavolini facilmente riconfigurabili grazie a un intuitivo sistema di fissaggio. Braccioli e accessori completano un design flessibile, perfetto per sale d'attesa, uffici, musei e aree di incontro. Sempre in movimento, sempre pronto a reinventarsi.

EN - Sys is a modular sofa, designed to adapt to ever-changing spaces. The 2, 3 and 4-seater painted steel structure can accommodate various types of seating and tables that can be easily rearranged thanks to a user-friendly fastening system. Armrests and accessories add the finishing touches to a flexible design, perfect for waiting rooms, offices, museums and meeting areas. Sys is always on the move, always open to reinventing itself.

[233]





[236]



[237]

SYS

[TECHNICAL DETAILS]

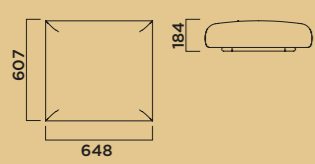

SYS
CUSHION MODULE

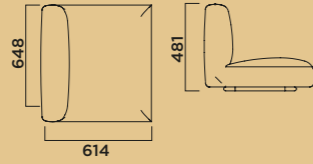

SYS
CUSHION MODULE WITH BACKREST

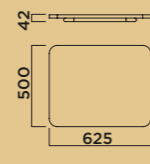

SYS
TABLE MODULE

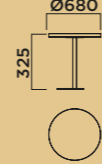

SYS
HIGH COFFEE TABLE



SYS
TWO-SEATER STRUCTURE MODULE

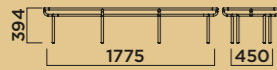

SYS
THREE-SEATER STRUCTURE MODULE



SYS
FOUR-SEATER STRUCTURE MODULE

Esempi di combinazioni finiture / Examples of finish combinations:



Black/Fiord F0451/Fiord F0271



Black/Guest GU0420/Guest GU0360/Guest GU0240



Black/Nuvole NV404/Nuvole NV704

EMBRACE



WAFFLE ONE [LOUNGE CHAIR]

Design: Favaretto&Partners

IT - Waffle One è un angolo di benessere dall'eleganza discreta, una poltroncina che accoglie e avvolge come un abbraccio. Il suo design modulare, che si esplicita al meglio nella versione Endless, permette di creare composizioni armoniose, mentre dettagli come il tavolino da bracciolo con gancio portaborse ed elettrificazione sotto seduta la rendono perfetta per uffici, hotel e spazi condivisi.

EN - Waffle One is a discreetly elegant oasis of well-being, a small armchair that envelops and embraces you, like a warm hug. Its modular design, at its best in the Endless version, is perfect for creating harmonious arrangements, while details such as the armrest table with bag hook and power sockets under the seat make it ideal for offices, hotels and communal areas.





[244]



[245]

WAFFLE ONE

[TECHNICAL DETAILS]

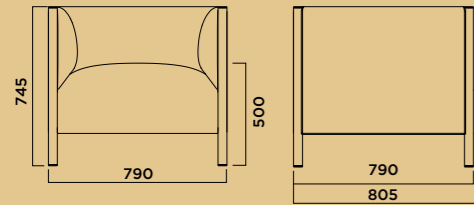

WAFFLE ONE

Esempi di combinazioni finiture / Examples of finish combinations:



Black fine textured/Rolla RL03



Black fine textured/Rolla RL03



Black fine textured/Rolla RL03



White embossed/Norfolk NF07



White embossed/Norfolk NF07



White embossed/Norfolk NF07



*Black fine textured/
Convert D CO7513*



*Black fine textured/
Convert D CO7513*



*Black fine textured/
Convert D CO7513*

ARCHI- TECTURE



[248]

MUSEUM

[BENCH]

Design: Giulio Lazzotti

IT - Museum si compone di forme leggere e linee sinuose; è una panca minimal e raffinata, che travalica le mode. Disponibile in tre dimensioni, si adatta con naturalezza agli spazi, senza bisogno di agganci. La finitura in rovere ne esalta la matericità, mentre la versione singola diventa un coffee table o uno sgabello, trasformando ogni stanza con eleganza discreta.

EN - Museum features light shapes and sinuous lines; it is a minimal and refined bench that transcends the bounds of fashion. Available in three sizes, it fits naturally into any space, with no need for connectors. The oak finish accentuates its tactile qualities, while the single unit can be used as a coffee table or a stool, adding a discreet touch of elegance to any room.

[249]





MUSEUM

[TECHNICAL DETAILS]



MUSEUM
STOOL

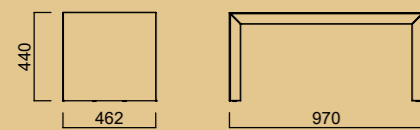

MUSEUM
2 SEAT

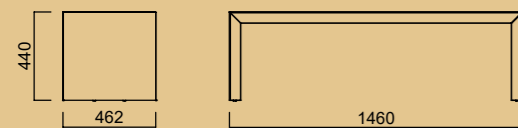

MUSEUM
3 SEAT

Esempi di combinazioni finiture / Examples of finish combinations:

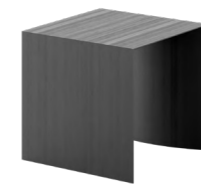

Black stained real oak



Black stained real oak



Black stained real oak



Natural real oak



Natural real oak



Natural real oak

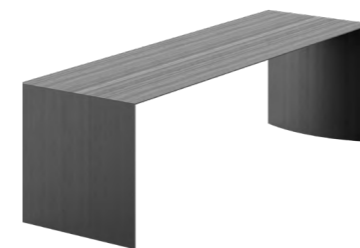

Black stained real oak



Black stained real oak



Black stained real oak

TABLES

FLEXIBI- LITY



VERSABLE

[TABLE]

Design: Robin Rizzini

IT - Versable trasforma lo spazio lavorativo in un ambiente fluido e dinamico. Modulari, riconfigurabili e disponibili in due altezze, questi tavoli si adattano con naturalezza a ogni contesto, dal lavoro individuale agli incontri informali. Forme essenziali, dettagli curati e accessori intelligenti – dall'elettrificazione alle ruote opzionali – rendono ogni configurazione funzionale e dinamica.

EN - Versable transforms workspaces into fluid and ever-changing environments. Modular, easy to reconfigure and available in two heights, these tables adapt naturally to any scenario, from single-user workstations to informal meetings. Essential lines, attention to detail and intelligent accessories – from power sockets to optional castors – make each version functional and versatile.





VERSABLE

[TECHNICAL DETAILS]



VERSABLE H710

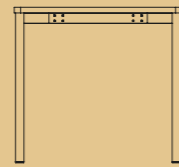

TABLE TOP SIZES (mm)
DIMENSIONI PIANI TAVOLO (mm)

800x1400	1000x2000
800x1600*	1000x3000
800x1800	1200x2400
800x2000	

* ALSO AVAILABLE WITH CASTORS



VERSABLE SQUARE H710



TABLE TOP SIZES (mm)
DIMENSIONI PIANI TAVOLO (mm)

800x800
1200x1200*

* ALSO AVAILABLE WITH CASTORS

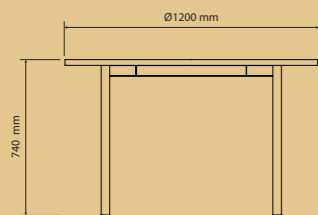

VERSABLE ROUND H710

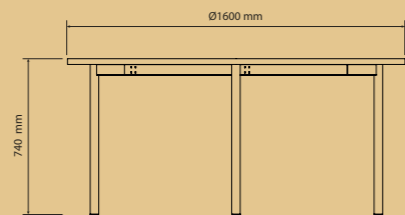
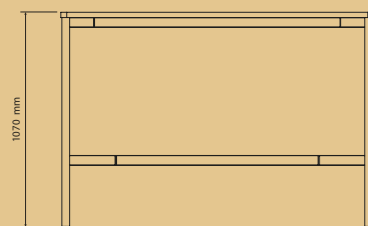

TABLE TOP SIZES (mm)
DIMENSIONI PIANI TAVOLO (mm)

Ø1200 - 4 legs*
Ø1600 - 3 legs

* ALSO AVAILABLE WITH CASTORS



VERSABLE MEETING H1070

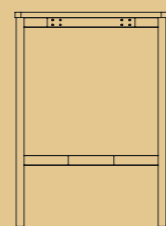

TABLE TOP SIZES (mm)
DIMENSIONI PIANI TAVOLO (mm)

800x1600*
800x2000*
1200x1200*

* ALSO AVAILABLE WITH CASTORS

Esempi di combinazioni finiture / Examples of finish combinations:



Oxide red/Maple



Oxide red/ oxide red ABS/ Maple



Oxide red/ oxide red ABS/ Maple



Red oxide/ Black



Oxide red/Oxide red ABS/ Black



Oxide red/Oxide red ABS/ Black



Reed green/Reed green ABS/Black



Reed green/Black



Reed green/Black



Reed green/Maple



Reed green/Reed green ABS/Maple



Reed green/Reed green ABS/Maple

**VERSATI-
LITY**



RECORD

[TABLE]

Design: mc.Dsg

IT - Record è una collezione di tavoli che si basa su linee pulite e dettagli studiati, come le gambe che si incastrano senza viti visibili. La versione Living, con il suo profilo ovale, esalta l'eleganza della collezione, mentre Record Meeting offre ampie superfici di lavoro, con opzione di elettrificazione. Per il settore horeca, Record Contract si declina in due altezze e numerose combinazioni di piani, perfetto per qualsiasi progetto di interior.

EN - Record is a collection of tables featuring clean lines and meticulous details, such as legs that slot together with no visible screws. The Record Living table, with its oval shape, shows off the elegance of the collection, while the Record Meeting table offers large work surfaces, with the option of adding power sockets. For the Ho.Re.Ca. sector, the Record Contract table is available in two heights and numerous top combinations, making it ideal for any interior design project.





[270]



[271]

RECORD

[TECHNICAL DETAILS]

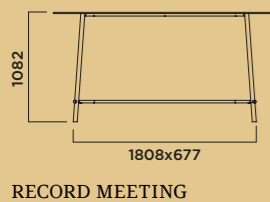
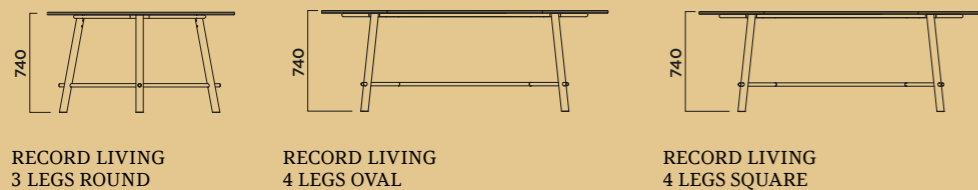
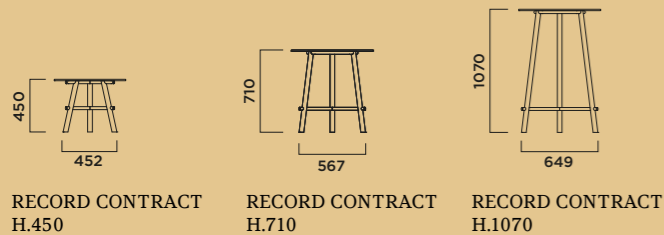

Esempi di combinazioni finiture / Examples of finish combinations:



Black/Black Fenix



Black/Black heritage oak



Natural solid oak/ Black heritage oak

COMPO- SITION



[274]

RIM

[TABLE]

Design: Cory Grosser

IT - Ispirati agli iconici occhiali tondi di Le Corbusier e Philip Johnson, i tavolini RIM giocano con geometrie ideali e proporzioni perfette. Il piano circolare in HPL e la struttura tubolare in metallo danno vita a un design riconoscibile, capace di trasformarsi attraverso composizioni dinamiche e accostamenti cromatici. Disponibili in diverse dimensioni e altezze, si inseriscono con facilità in lounge, spazi horeca e sale d'attesa, mentre la versione di servizio si abbina perfettamente a divani e aree relax.

EN - Inspired by the iconic round glasses of Le Corbusier and Philip Johnson, the RIM coffee tables experiment with ideal geometric shapes and perfect proportions. Together, the circular HPL top and tubular metal structure create a distinctive design that can be transformed into ever-changing combinations of shapes and colours. Available in different sizes and heights, they can easily be placed in lounges, hospitality areas and waiting rooms, while the coffee table version is the perfect accompaniment for sofas and relaxation areas.

[275]





[278]



[279]

RIM

[TECHNICAL DETAILS]

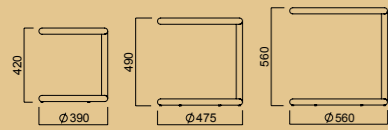

RIM
SIDE TABLES

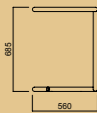

RIM
SERVING TRAY

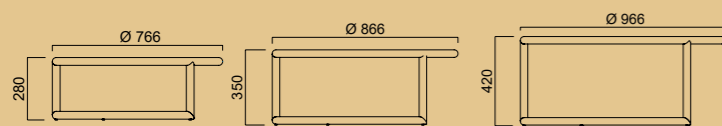

RIM
COFFEE TABLES

Esempi di combinazioni finiture / Examples of finish combinations:



Sand/Dove grey/Universe blue



Sand/Dove grey/Universe blue



Sand/Dove grey/Ochre yellow



Sand/Dove grey/Ochre yellow



Black/Oxide red/Dove grey



Black/Oxide red/Dove grey

EFFI- CIENCY



[282]

JIT [TABLE]

Design: Gregorio Facco

IT - La geometria prende vita in Jit, un tavolino che unisce rigore e leggerezza in un disegno perfetto. Il telaio in tubo d'acciaio si incastra con grazia, creando una base stabile e raffinata. Disponibile con tre razze o a piramide, in diverse altezze, può essere impilato grazie al meccanismo reclinabile del top, adattandosi con naturalezza a bar e ristoranti.

EN - Geometry takes shape in Jit, a coffee table that combines rigorous design and visual lightness to perfection. The steel tube frame fits together gracefully, creating a base that is both stable and refined. Available with three legs or in a pyramid shape and in different heights, it can be stacked thanks to the tilting mechanism of the top, easily fitting into cafés and restaurants.

[283]





[286]



[287]

JIT

[TECHNICAL DETAILS]

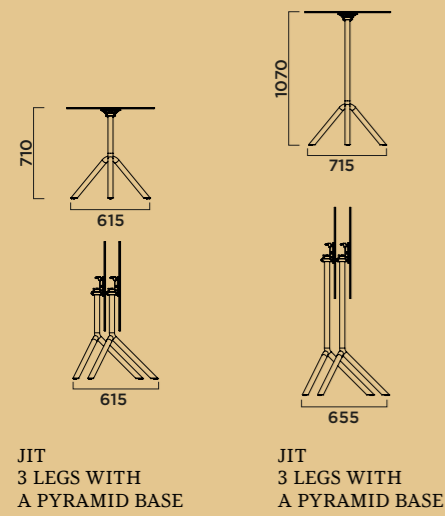
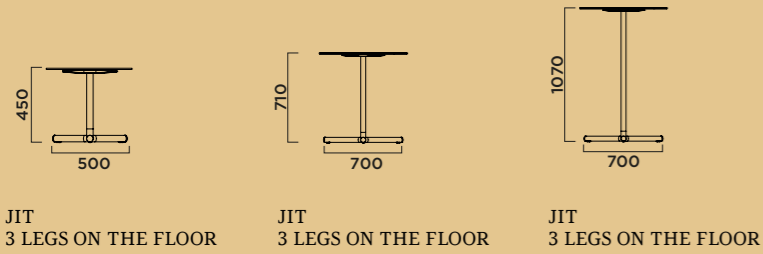

Esempi di combinazioni finiture / Examples of finish combinations:



Ochre yellow/Ochre yellow HPL



Ochre yellow/Light grey RFS



Ochre yellow/Ochre yellow HPL



Oxide red/Oxide red HPL



Oxide red/D'ecò brown RFS



Oxide red/Oxide red HPL



Dove grey/ Dove grey HPL



Dove grey/Light grey RFS



Dove grey/ Dove grey HPL



Embossed black/Black HPL



Embossed black/Black HPL



Embossed black/Black HPL

SOPHI-
STICA-
TION



[290]

FELUCA

[TABLE]

Design: BrogliatoTraverso

IT - Il segno distintivo diventa struttura: la base ellittica di Feluca Table richiama il telaio dell'omonima sedia, dando vita a una collezione di tavolini per il mondo horeca. Disponibili in due altezze e con basi fisse o reclinabili, si abbinano a una varietà di piani per creare combinazioni sempre nuove. Leggeri, versatili e perfettamente armonici, portano ovunque il tratto inconfondibile di Feluca.

EN - Its signature element evolves into its structure: the elliptical base of the Feluca Table calls to mind the frame of the chair with the same name, leading to the creation of a collection of occasional tables for the Ho.Re.Ca sector. Available in two heights and with fixed or reclining bases, the tables can be combined with a variety of tops to create ever-changing combinations. Light, versatile and perfectly proportioned, they convey the unmistakable Feluca flair everywhere.

[291]





[294]



[295]

FELUCA TABLE

[TECHNICAL DETAILS]

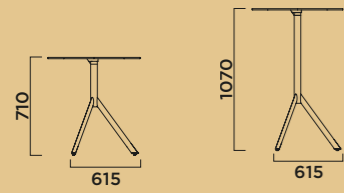

FELUCA TABLE
3 LEGS H.710

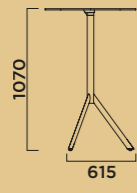

FELUCA TABLE
3 LEGS H.1070

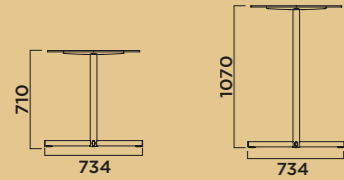

FELUCA TABLE
4 LEGS H.710

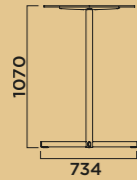

FELUCA TABLE
4 LEGS H.1070

Esempi di combinazioni finiture / Examples of finish combinations:



Dove grey/ Dove grey HPL



Dove grey/ Dove grey HPL



Dove grey/ Dove grey HPL



Oxide red/Oxide red HPL



Oxide red/Oxide red HPL



Oxide red/Oxide red HPL



Ochre yellow/Ochre yellow HPL



Ochre yellow/Ochre yellow HPL



Ochre yellow/Ochre yellow HPL



Embossed black/Black HPL



Embossed black/Black HPL



Embossed black/Black HPL

BA- LANCCE

FLINK [TABLE]

Design: Thomas Pedersen

IT - Dalla purezza delle forme di Flink nasce un tavolino statuario, perfetto per il mondo della ristorazione. La solida base rotonda richiama l'omonimo sgabello, ottimizzando lo spazio e accogliendo con naturalezza più persone. Realizzato in acciaio verniciato, è disponibile in due altezze e in finitura per esterni, adattandosi con equilibrio e discrezione a ogni contesto.

EN - Inspired by the purity of Flink's shapes, a statuesque table is born, perfect for the restaurant world. The solid round base is reminiscent of the stool with the same name, optimising space and comfortably accommodating several people. Made of painted steel, it is available in two heights and with an outdoor finish, blending harmoniously and discreetly into any setting.



[300]



[301]



[302]



[303]

FLINK TABLE

[TECHNICAL DETAILS]

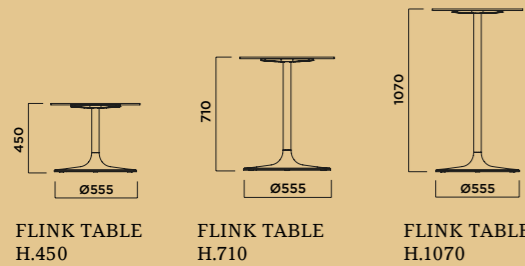

FLINK TABLE
H.450

FLINK TABLE
H.710

FLINK TABLE
H.1070

Esempi di combinazioni finiture / Examples of finish combinations:



Dove grey/ Dove grey HPL



Dove grey/ Dove grey HPL



Dove grey/ Dove grey HPL



Oxide red/Oxide red HPL



Oxide red/Oxide red HPL



Oxide red/Oxide red HPL



Ochre yellow/Ochre yellow HPL



Ochre yellow/Ochre yellow HPL



Ochre yellow/Ochre yellow HPL



Embossed black/Black HPL



Embossed black/Black HPL



Embossed black/Black HPL

ALSO WORTH DISCOVERING



BEETLE
Giancarlo Bisaglia



DEMOISELLE
Quaglio Simonelli



PURE LOOP LOUNGE
Claus Breinholt



FIGURELLINA
Fabrizio Batoni



NEXT
Andreas Ostwald



CALLITA
Andreas Ostwald



PICAPAU
Radice Orlandini



BOBO
Fabrizio Batoni



WAFFLE ENDLESS
Favaretto&Partners



COOKIE
Marcello Ziliani



NOW
Stefano Sandonà



DROP
Radice Orlandini



ROUND
infiniti R&D



PLANO TABLE
infiniti R&D



DROP
Radice Orlandini



LOOP TABLE
Claus Breinholt



PURE LOOP BINUANCE
Claus Breinholt



PURE LOOP MAXI
Claus Breinholt



FREYA
Claus Breinholt



FORMULA
BrogliatoTraverso



RECORD BENCH
mc.Dsg



DESIGNERS

- ANDREAS OSTWALD
- BROGLIATOTRAVERSO
- CLAUS BREINHOLT
- CORY GROSSER
- DORIGO DESIGN
- FABRIZIO BATONI
- FAVARETTO&PARTNERS
- GIANCARLO BISAGLIA
- GIO TIROTTO
- GREGORIO FACCO
- KAI STANIA
- KLAUS NOLTING
- MARCELLO ZILIANI
- NEEDS STUDIO
- OLEG PUGACHEV
- PHILIPPE TABET
- QUAGLIO SIMONELLI
- RADICE ORLANDINI
- ROBIN RIZZINI
- STEFANO SANDONÀ
- STUDIO DESSÌ
- THOMAS PEDERSEN

infiniti reserves the right to introduce any changes to its own models, without prior notice.

The printing ink cannot exactly reproduce the colours. For higher accuracy with suggest inspecting the colour samples.

Images:

[BRUGER STUDIO]

brugerstudio.com

Photos:

[STUDIO EYE]

Set designer:

[BEPPE MANGIA / STUDIO EYE]

eye-studio.it

Colour separation
and Print:

[GRAFICHE GEMMA]

grafichegemma.it

[PHOTOGRAPHERS OF THE PROJECTS]

Valentina Verdesca

Bruno Gallizzi

Chris Abatzis

Saverio Lombardi Vallauri

Jeoffrey Gabriel Imagoshootz

Nathan Robberechts

Alessandro Saletta – DSL Studio

Clearspacephotography

Stefano Anzini

Chris Abatzis

Shai Epstein

Sara Rosato

Fabio Fantolino

Yoav Peled

Giuliano Radici Photographer

Chinnici srl

Copyright:

infiniti 2025

*via Ca'Leoncino n° 2
31030 Castello di Godego
Italy*

infiniti
infinitidesign.it

infiniti



c. Joan Torruella i Urpina, 13 |
08758 Cervelló | Barcelona |
Tel. 34-936 600 640 | Fax 39-936 842 716 |
e-mail: vilaimport@vilaimport.com |
web: www.vilaimport.com