

CONCRET

2023

TAPICERIA



SOFÁS

NEW YORK	7
PALACE	13
PALAZZINA	19
TEMPLE	23
OASIS	29
CIELO	33
FORMA	39
GIANNI	45
VOLA	51
VOLARE	57
BERRY	61
PARMA	67
JULIA & ROMEO	71
INFORMACIÓN TÉCNICA	77
POUFS	81
MESAS DE CENTRO	83

SOFÁS CAMA

TOMMY	89
ERIC	93
STAN	95
JACK	97
TAPIZADOS	125

CAMAS

VICTORIA PLAIN	101
VICTORIA QUILT	103
NAXOS	105
BAHAMAS	107
MARTINICA	109
PACIFIC - MALIBU	111
MARIANNE	113
PHUKET	115
SAMAR	117
DEVON	119
SOMIERES	121
CARACTERÍSTICAS TÉCNICAS	123
TAPIZADOS	125

CONCRET

Tapicería

SOFÁS

NEW YORK	7
PALACE	13
PALAZZINA	19
TEMPLE	23
OASIS	29
CIELO	33
FORMA	39
GIANNI	45
VOLA	51
VOLARE	57
BERRY	61
PARMA	67
JULIA & ROMEO	71
INFORMACIÓN TÉCNICA	77
POUFS	81
MESAS DE CENTRO	83

NEW YORK

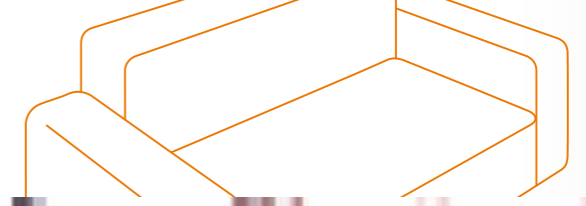

NEW YORK

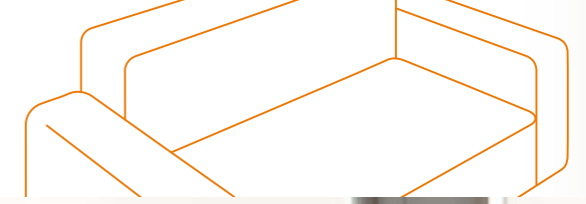

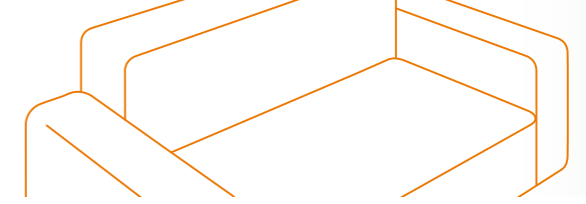

SOFÁ NEW YORK

Inspirado en la Ciudad que nunca duerme, es un modelo singular de formas originales y curvas asimétricas. El sofá se adapta perfectamente a cualquier diseño de espacio y convive con cualquier diseño de mobiliario o estilo. Ofrece un amplio espacio de relajación compartida o individual propia de la libertad del propio modelo.

Dimensiones

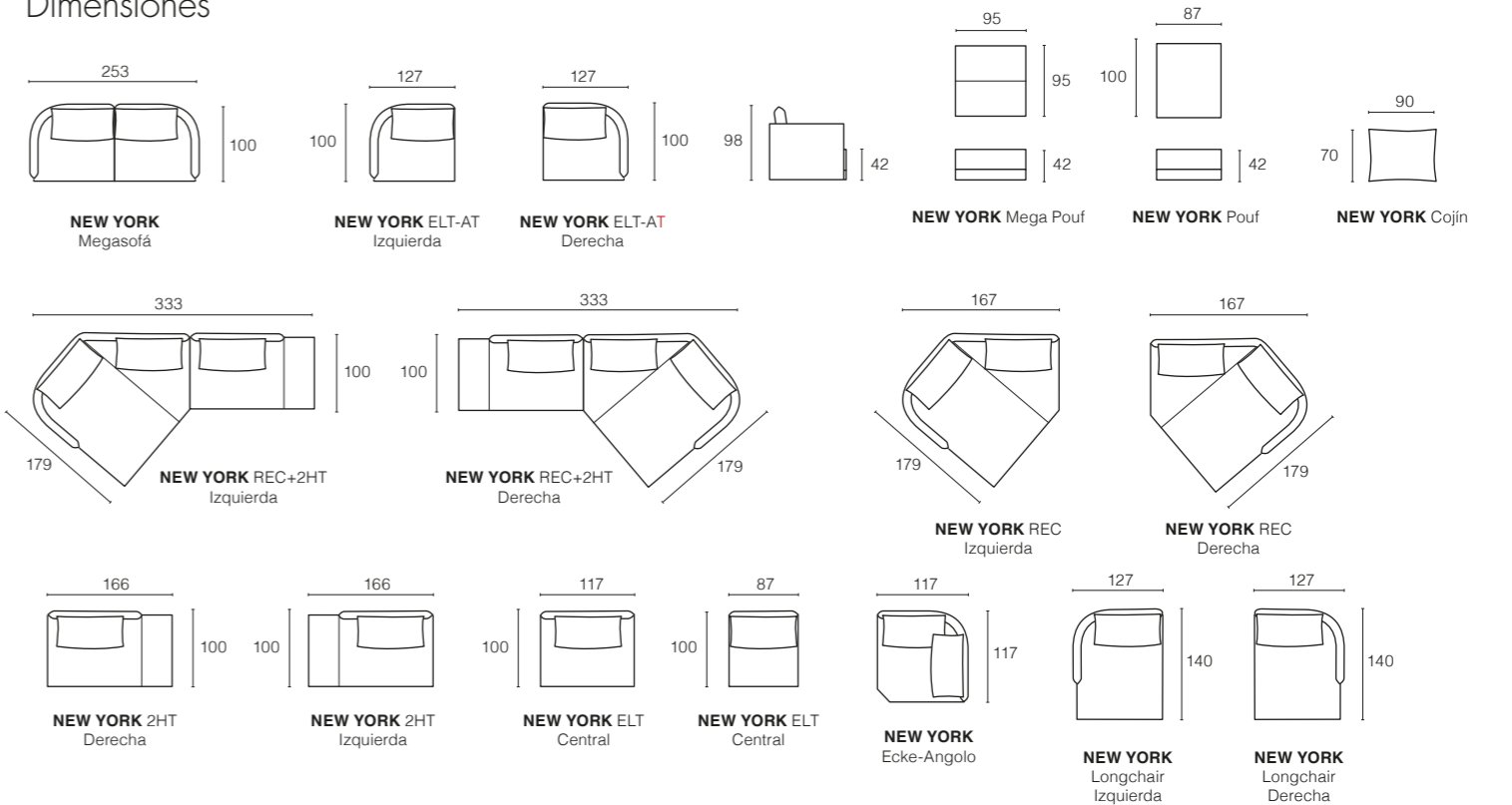

PALACE



PALACE

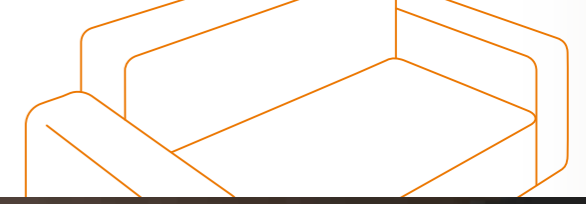

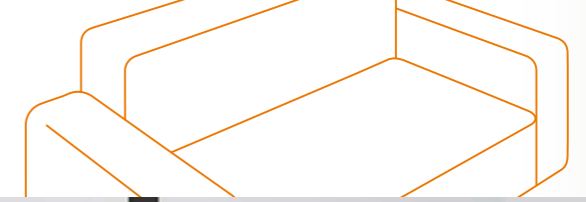

SOFÁ **PALACE**

El nombre lo dice todo: Palacio es un verdadero palacio. Los diferentes módulos ofrecen espacio adicional ya sea para sentarse o tumbarse cómodamente. Los diferentes elementos se pueden combinar en infinitas composiciones de forma que cada uno puede construirse su "palacio". De esta manera cada hogar es único e individual.

Dimensiones

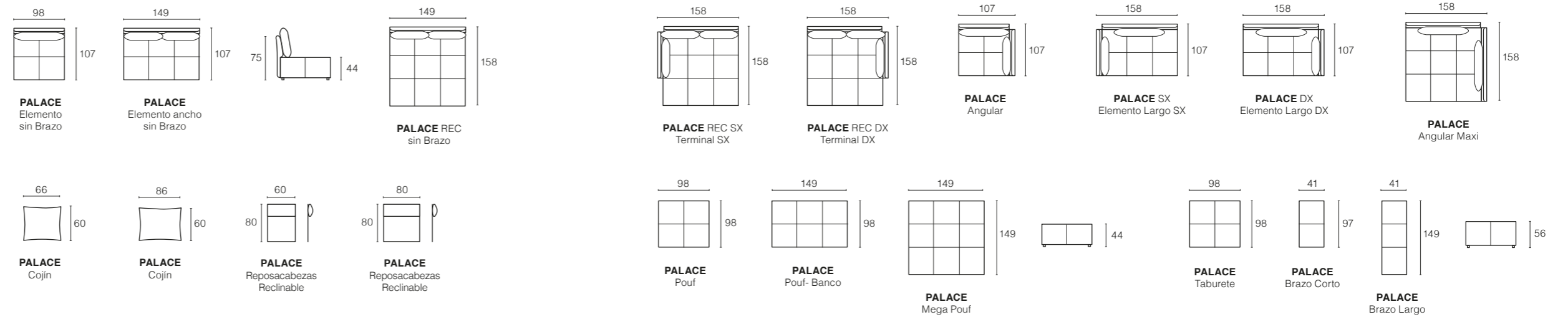

PALAZZINA

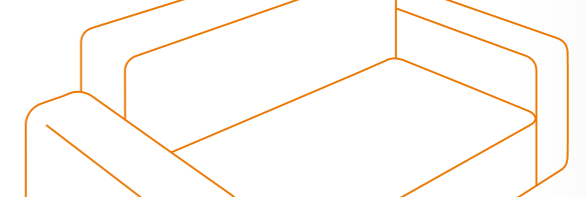

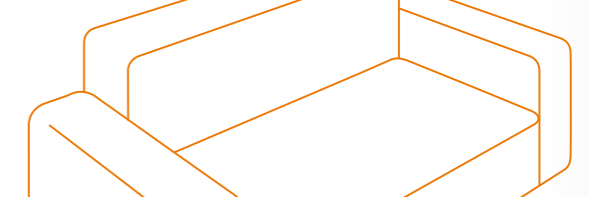

SOFÁ PALAZZINA

Las dimensiones de Palazzina permiten una mayor versatilidad para crear un ambiente de auténtica mansión. Los diferentes módulos ofrecen espacio adicional ya sea para sentarse o tumbarse cómodamente. Los diferentes elementos se pueden combinar en infinitas composiciones. De esta manera cada hogar es único e individual.



Dimensiones

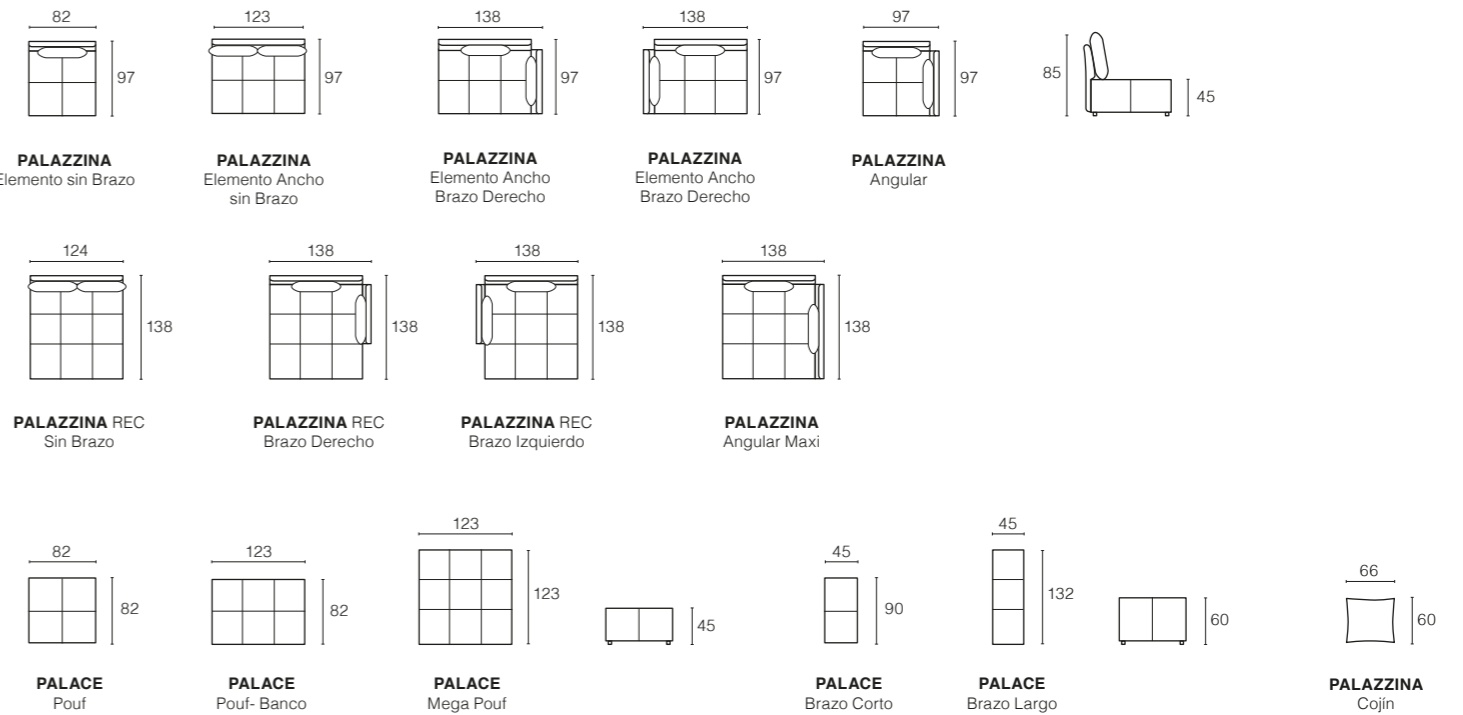

TEMPLE



TEMPLE



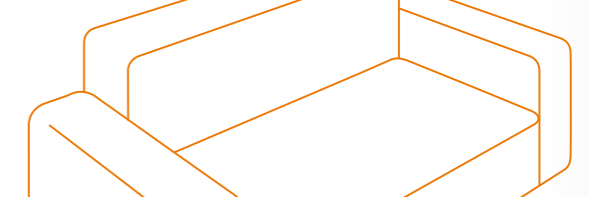

SOFÁ TEMPLE

Modelo diseñado bajo la influencia de los años 60 y 70, mezclando el estilo del "Chester" y del "Capitonné". Modelo formado por módulos que permiten un diseño libre al gusto del consumidor. Se caracteriza por su profundidad que le da un aire informal a la sentada, si bien el movimiento del respaldo lo transforma en una sentada más tradicional. Modelo extremadamente cómodo.

Dimensiones

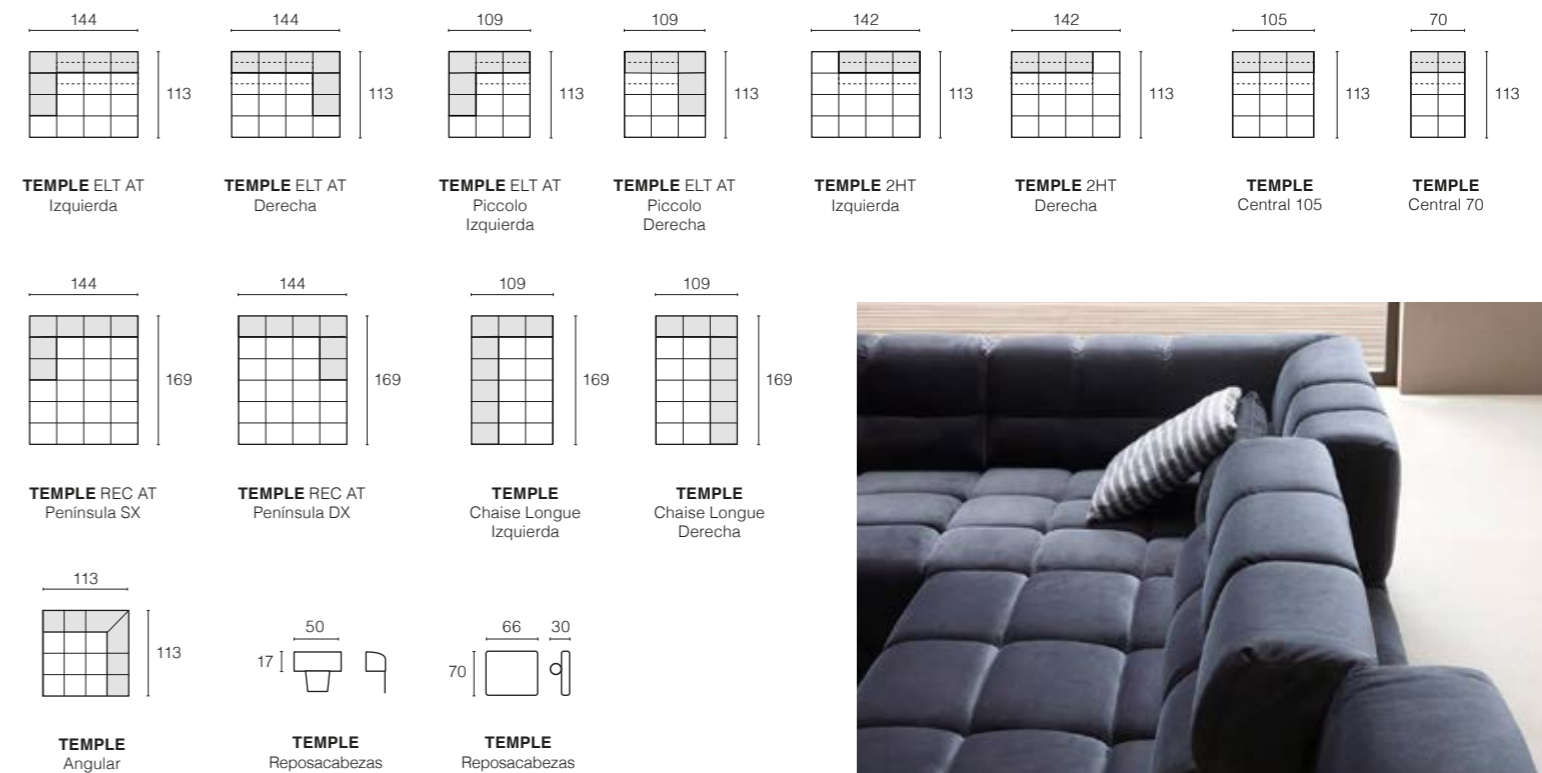
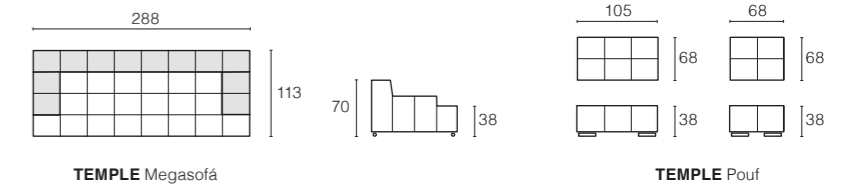

OASIS

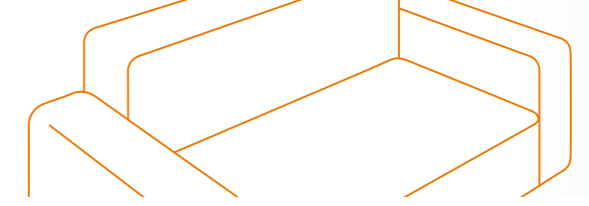

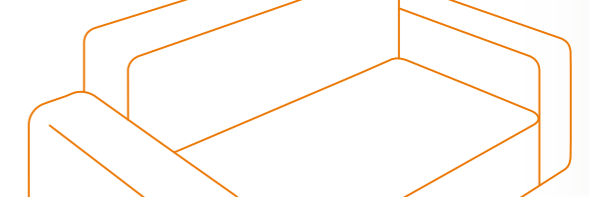

SOFÁ OASIS

La belleza flexible: un templo de comodidad. El bello carácter del Oasis está inspirado tanto en el Chesterfield y Capitoné, influenciado por los años 60 y 70. La firma de esa época se revela en la libertad, un estilo informal de sofá.

Oasis no pone límites a tu imaginación gracias a su enorme variedad de módulos y funcionalidad.

Dimensiones

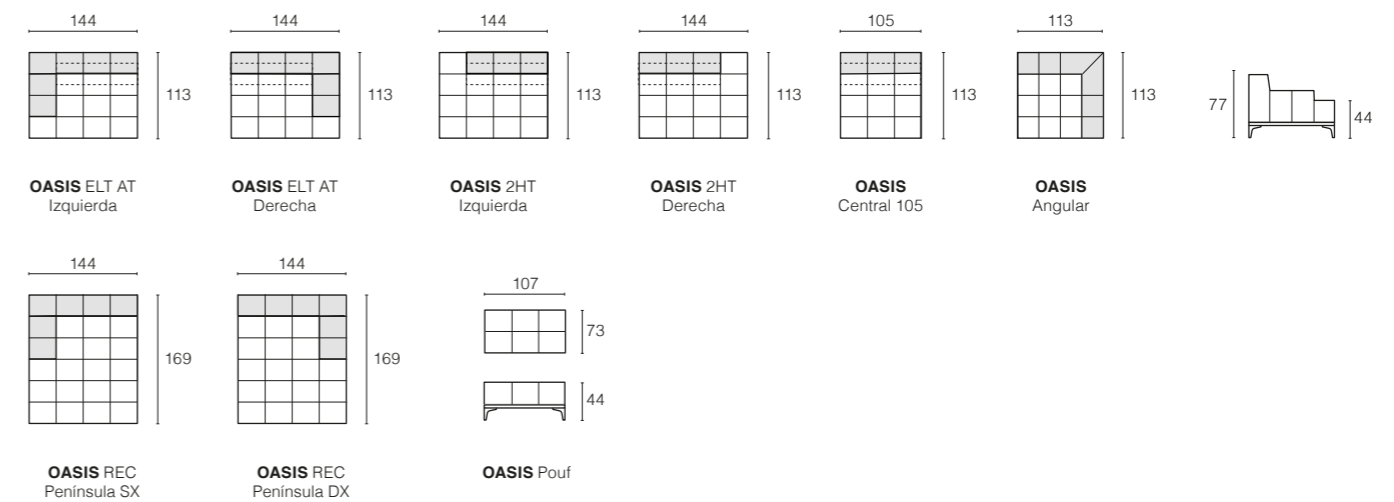

CIELO

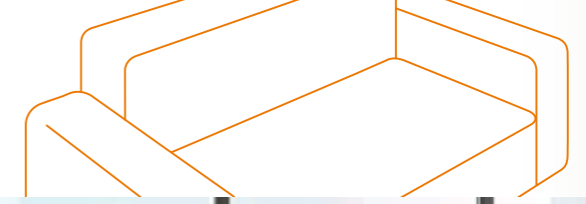

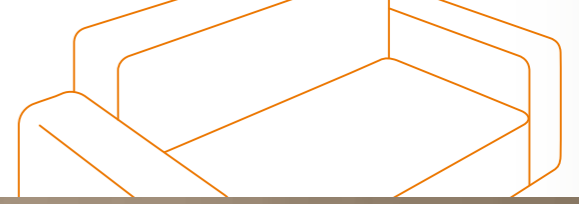

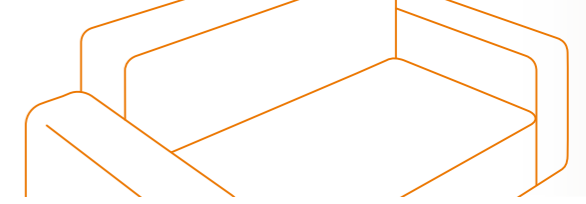

SOFÁ CIELO

El nombre del sofá, Cielo, se inspira en la comodidad del modelo. Formado por módulos que permiten un diseño libre al gusto del consumidor con una altura del respaldo óptima para su comodidad. Se caracteriza por su profundidad que le da un aire informal a la sentada, si bien el movimiento del respaldo lo transforma en una sentada más tradicional. Modelo extremadamente cómodo por el componente de Visco en su estructura.



Dimensiones

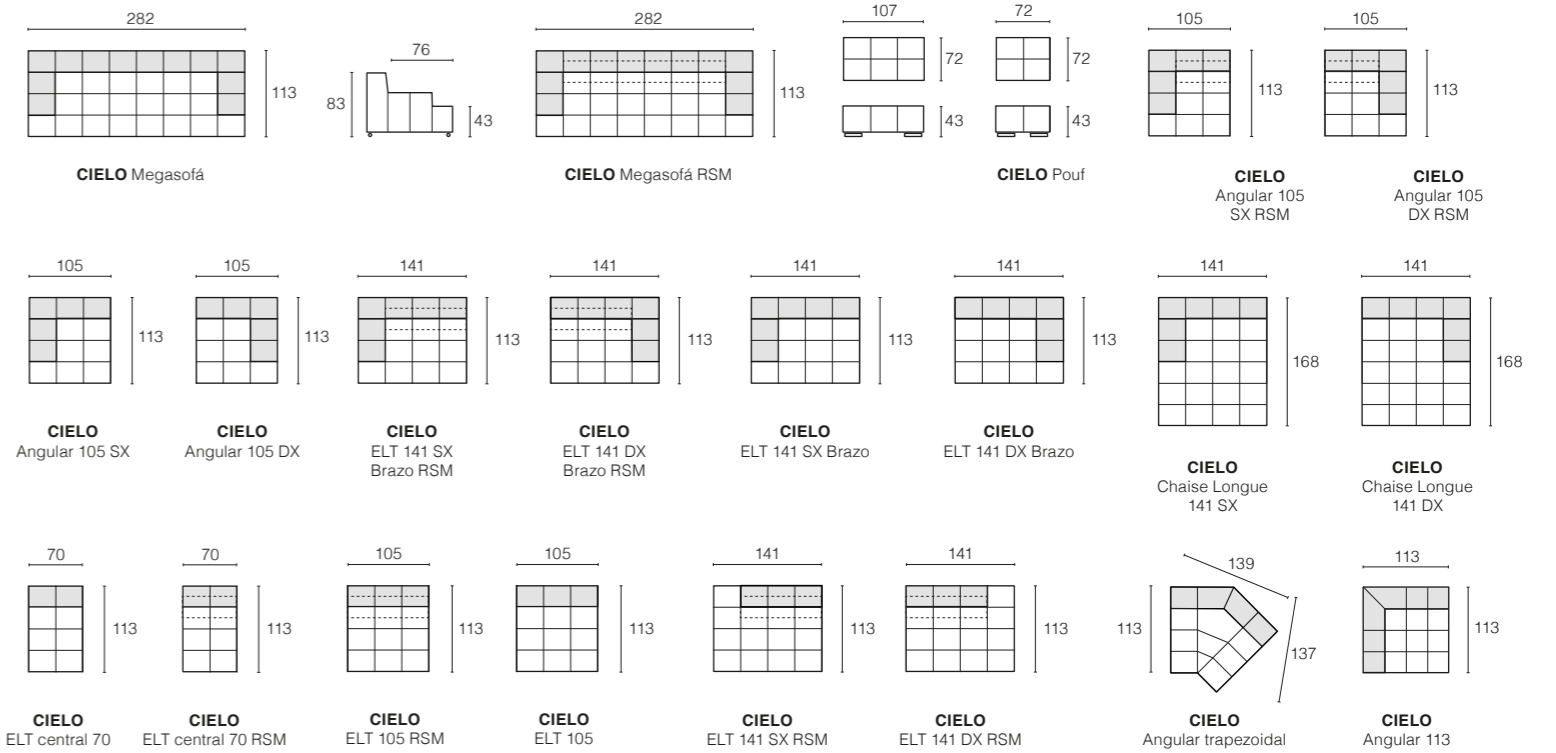

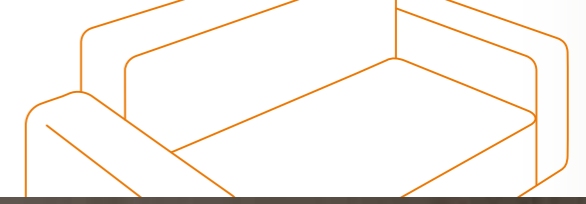

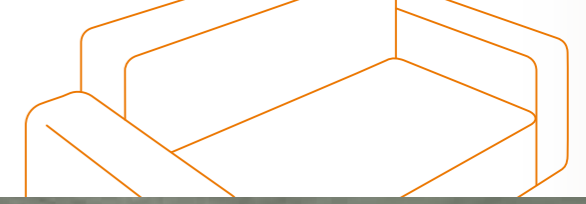

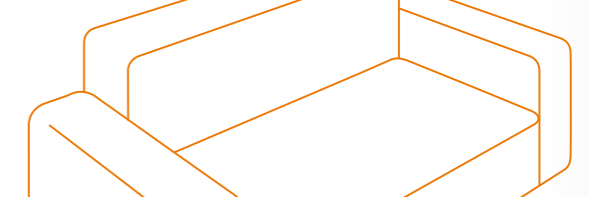

SOFÁ **FORMA**

Modelo que se caracteriza por su elegancia, modernidad, y su alto nivel de calidad y comodidad. De diseño cubista se marcan las líneas de cada asiento y respaldo y lo convierten en atemporal. Además dispone de un reposacabezas opcional perfectamente ajustable lo que aumenta la comodidad de la sentada.

Dimensiones

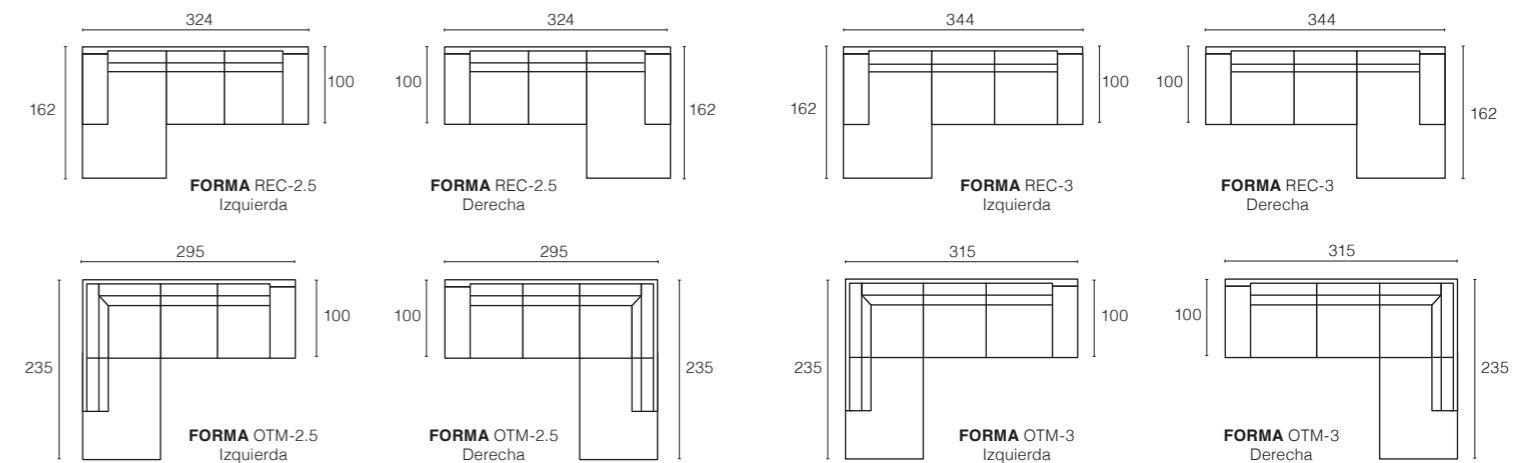
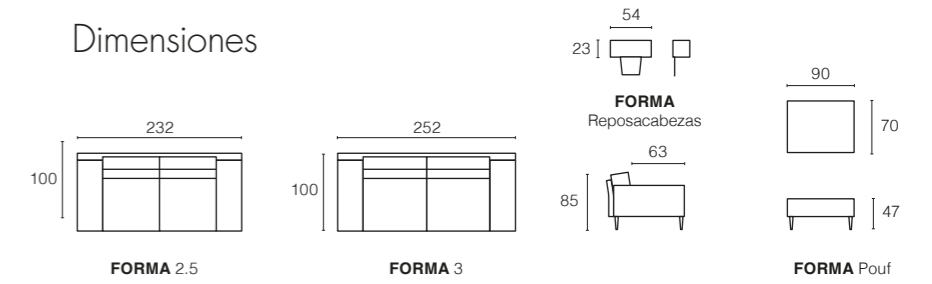

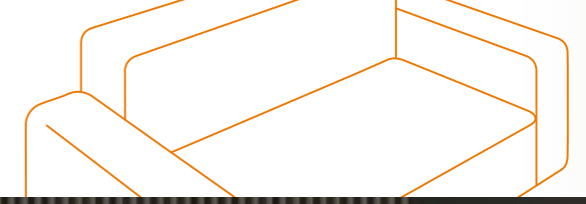

GIANNI

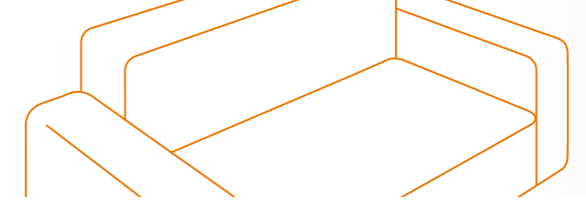

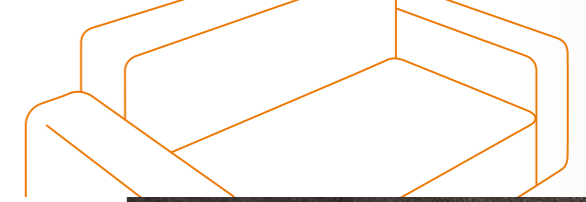
SOFÁ **GIANNI**

Modelo elegante y moderno de alta calidad y extremada comodidad. El respunteado le da un aire informal que permite adaptarse en cualquier espacio: un elegante salón o un apartamento urbano. Los cojines cuentan con un protagonismo importante aportando elegancia a cada composición. Pieza opcional de reposacabezas para completar la comodidad, sin perder la elegancia.

Dimensiones

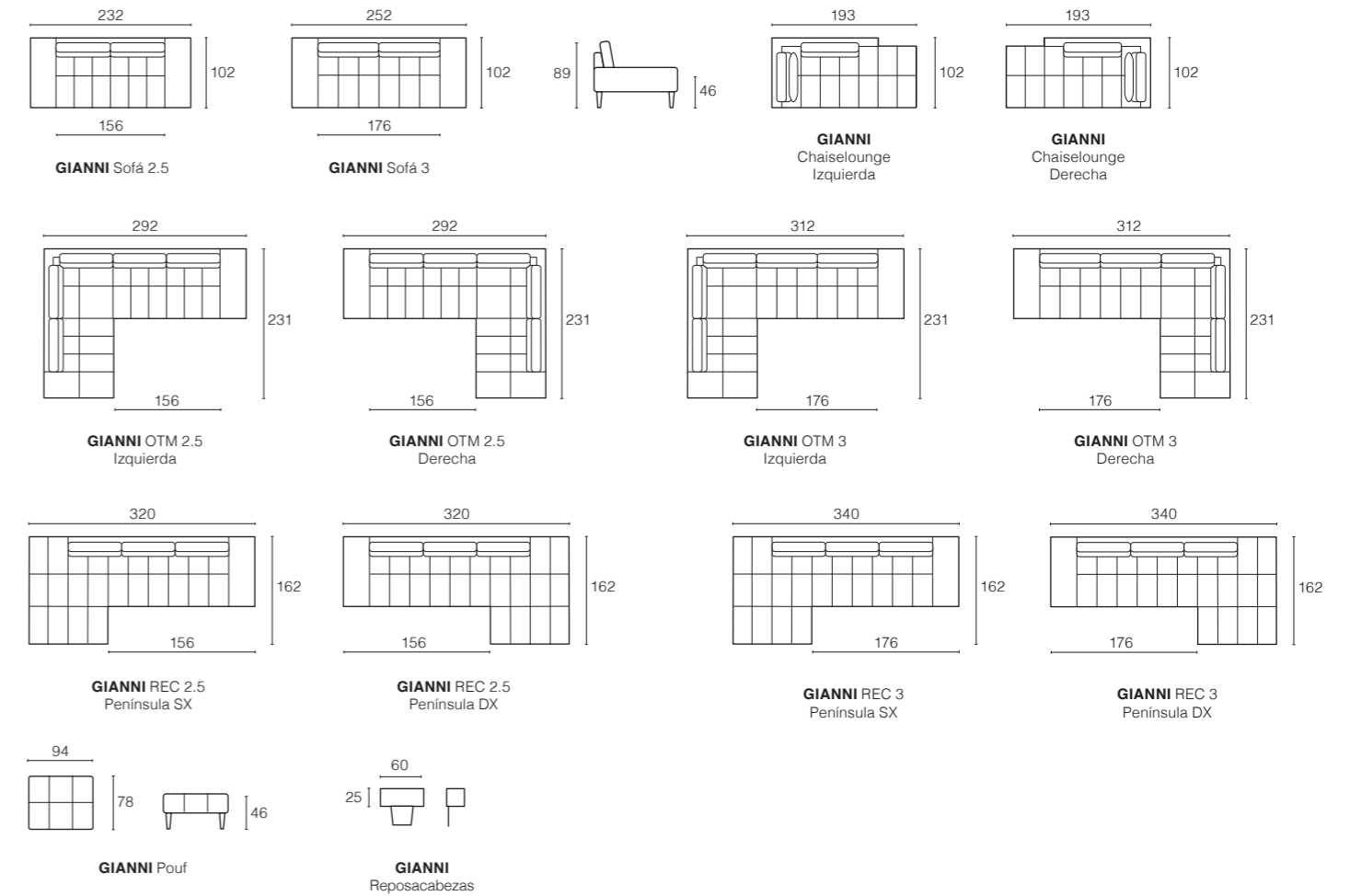

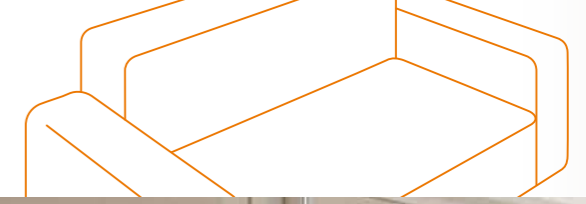

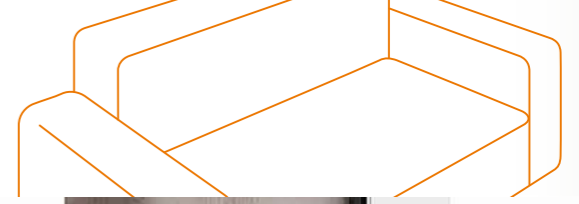

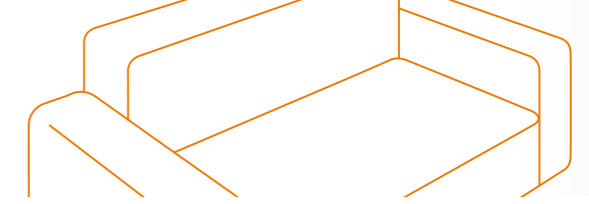

SOFÁ VOLA

Tentadoramente encantador: no puedes evitar amar a Vola. Los asientos anchos combinados con apoyabrazos en forma de alas brindan un acabado elegante, dando al sofá un nivel de exclusividad.

Acabado con telas exquisitas o piel de alta calidad. Los accesorios completan un look armonioso.

Dimensiones

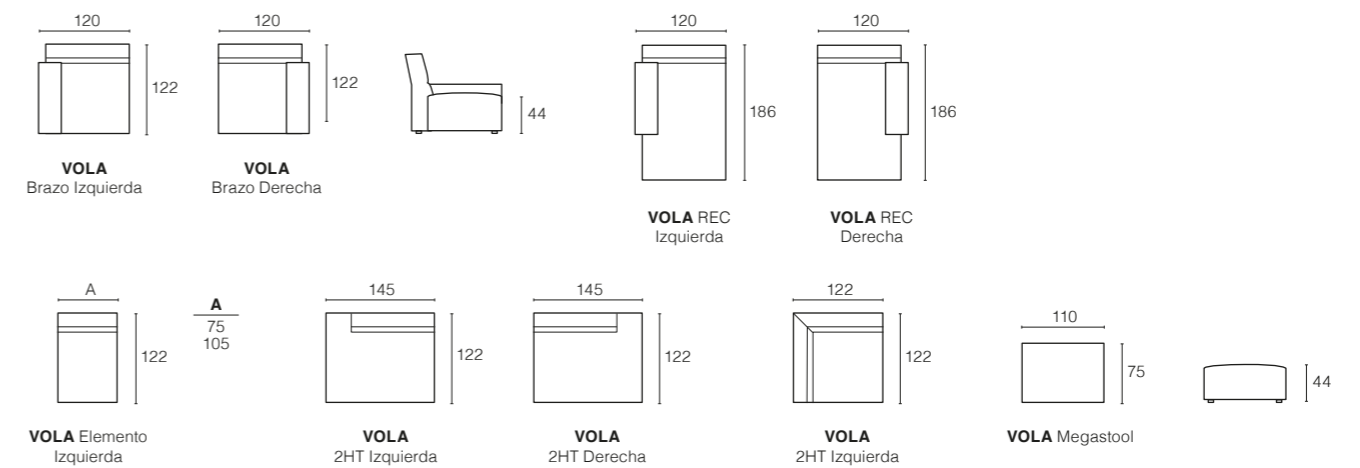

VOLARE

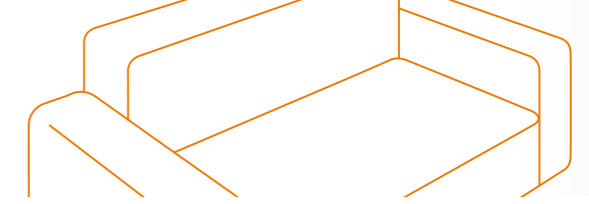



SOFÁ **VOLARE**

Tentadoramente encantador: no puedes evitar amar a Volare. Los asientos anchos combinados con apoyabrazos planos brindan un acabado elegante, dando al sofá un nivel de exclusividad.

Acabado con telas exquisitas o piel de alta calidad. Los accesorios completan un look armonioso.

Dimensiones

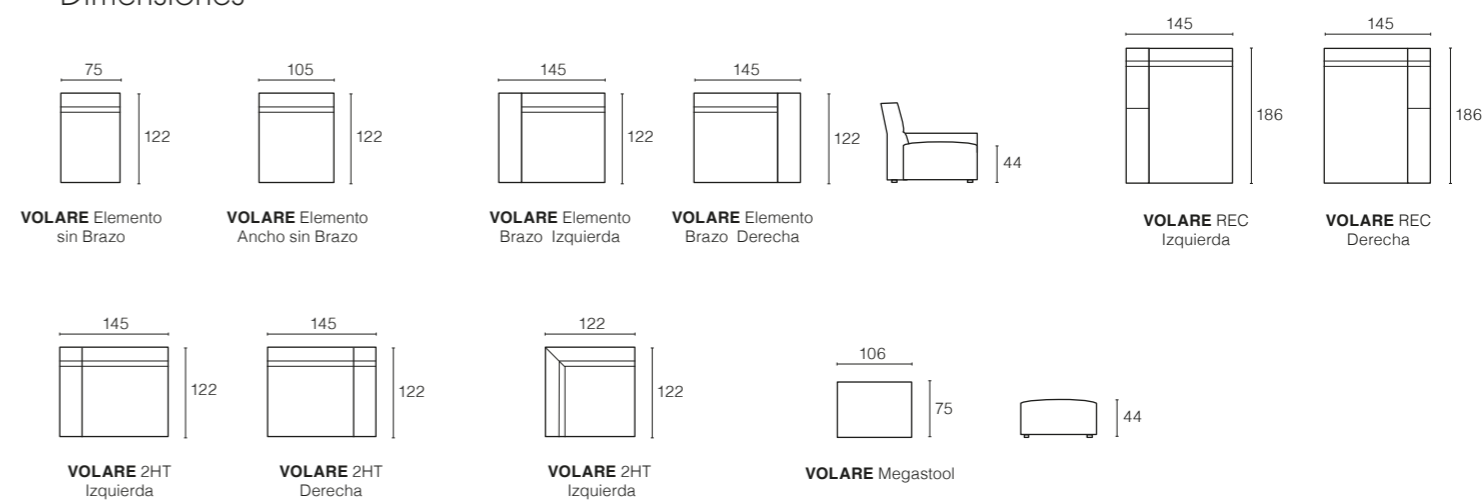

BERRY

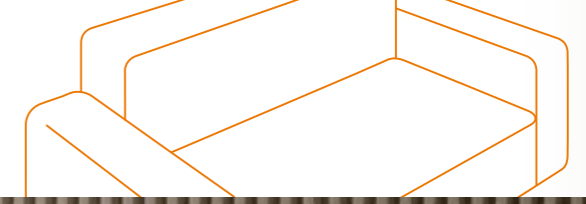

BERRY



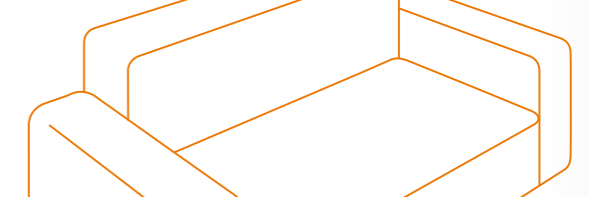

SOFÁ BERRY

Encantador y atractivo... Se dice que Berry es el Don Juan de los sofás de Concret. Berry es verdaderamente irresistible y seductor. Berry te invita directamente a relajarte y tomar un descanso.

Es el rey imbatible de la calidad del asiento. Las plumas están elegantemente cosidas en pequeños bolsillos de tela. El resultado es mayor resistencia, densidad comprimida y robustez estable.

Dimensiones

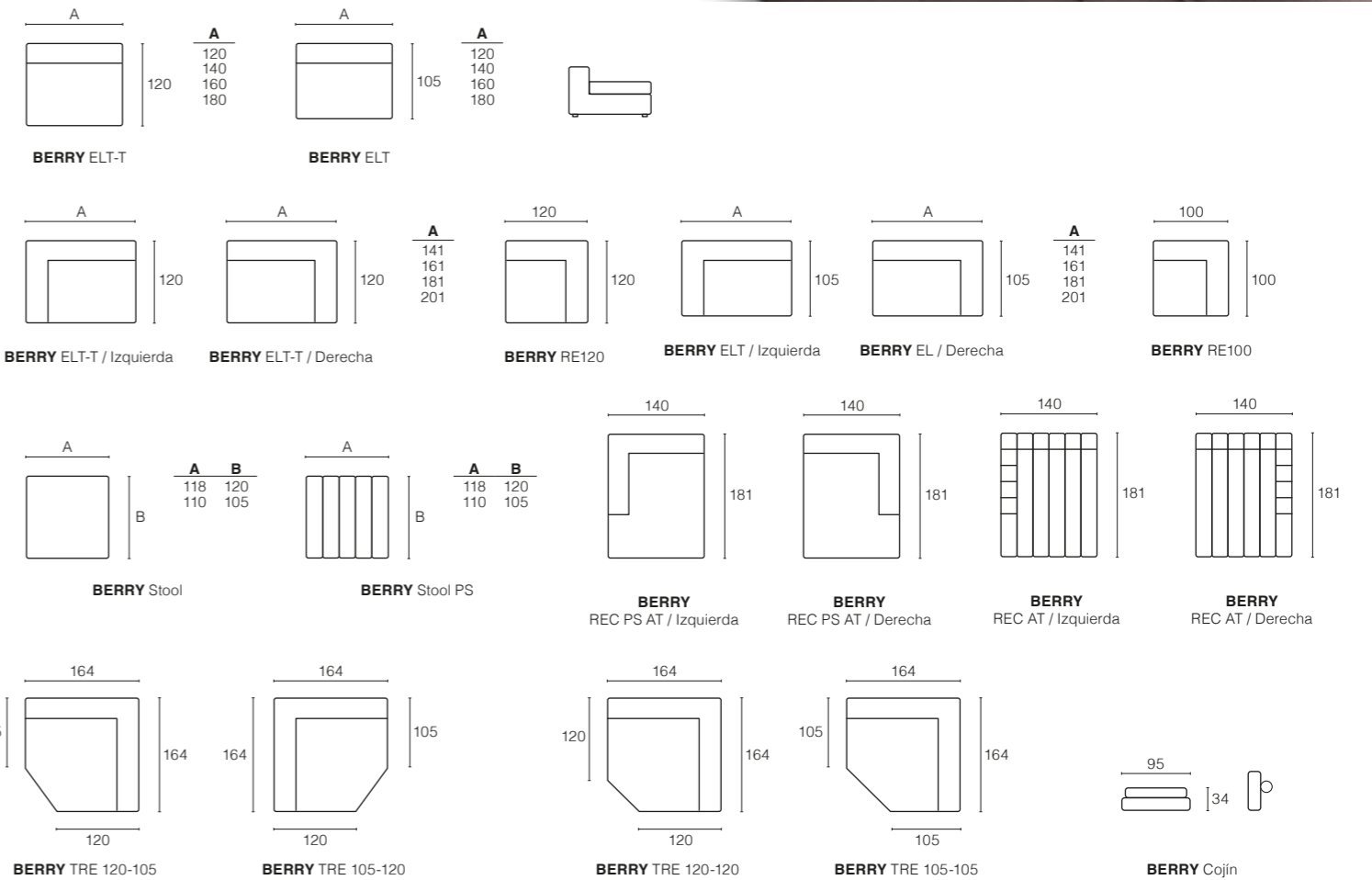



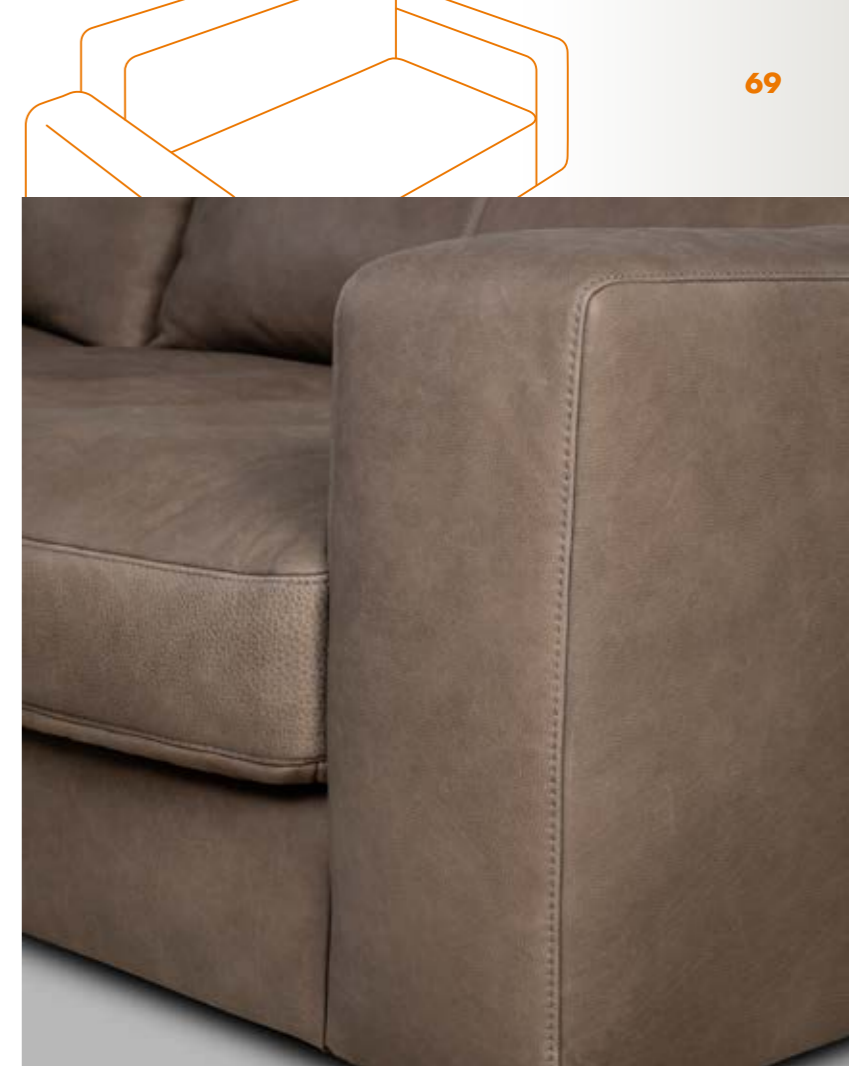

SOFÁ **PARMA**

Para tomarse un tiempo para ti mismo: las amplias superficies y la tierna suavidad crean una acogedora sensación de satisfacción y pura relajación. Cierra los ojos y siente cómo la rutina diaria se disipa suavemente.

Parma: grande, inmenso, magnífico.

Dimensiones

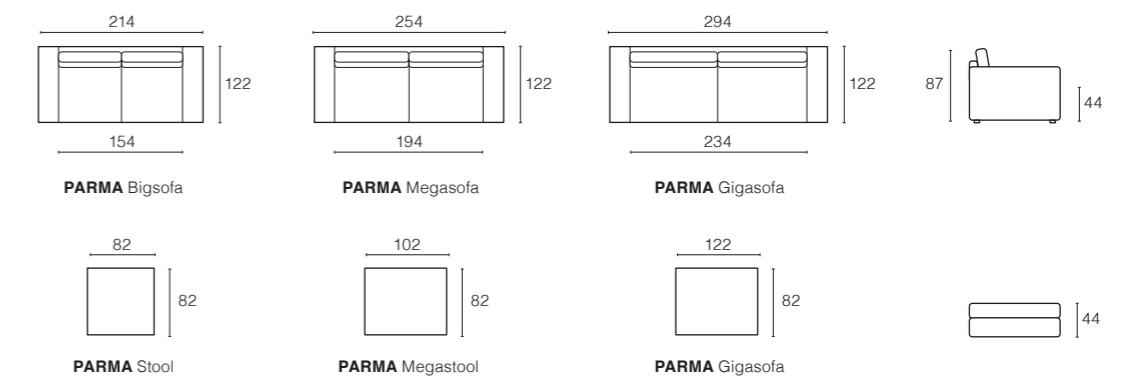

JULIA & ROMEO



JULIA & ROMEO

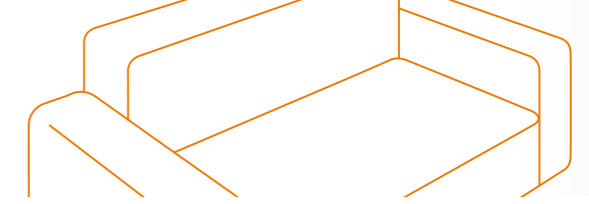

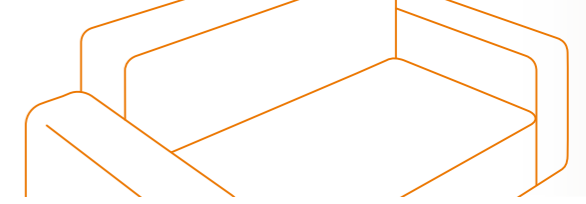

SILLÓN **JULIA&ROMEO**

Conjunto de sillones relax que dan elegancia a cualquier espacio y que se complementan perfectamente a cualquiera de los modelos de sofás que presentamos.

Las telas propuestas para cada pieza maximizan su comodidad. Pouf complementario. Posibilidad de tapizar en tela, piel o combinando la estructura en piel y el asiento en tela. Pies en negro o cromado Star o Spider.

Opciones de pies

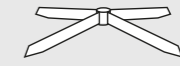

Star



Spider

Dimensiones

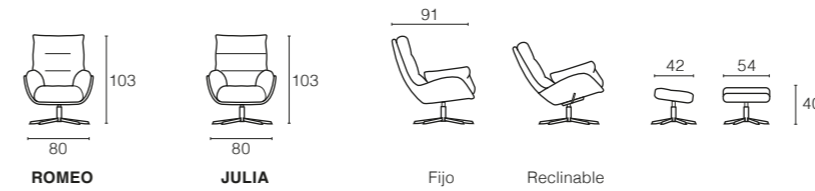



SOFÁ NEW YORK

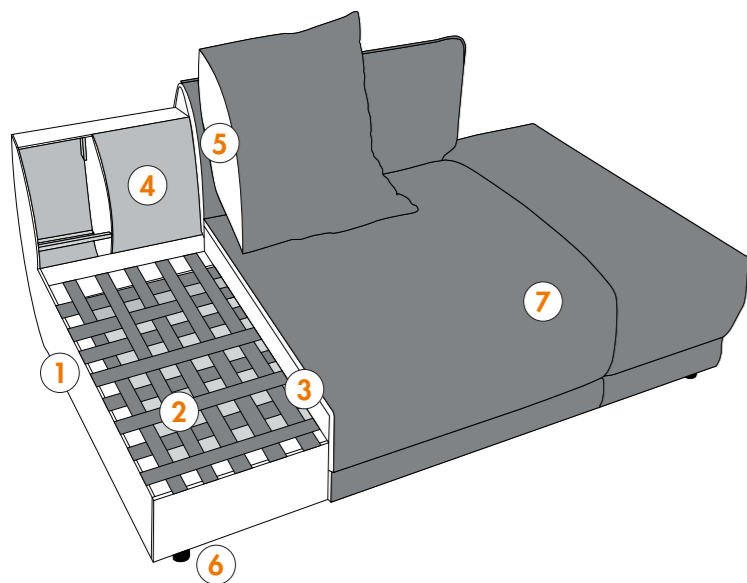

1. Estructura: Madera de haya.
2. Base del asiento: correas de tapicerías flexibles.
3. Relleno del asiento: espuma PUR altamente elástica sin CFC (densidad 35 kg/m³) envuelta en espuma viscosa de alta calidad (densidad 45kg/m³).
4. Estructura del asiento: correas de tapicerías flexibles.
5. Relleno del respaldo: cojines sueltos con rellenos de plumas de primera calidad.
6. Patas: Soporte de plástico de color negro de 3 cm de altura.
7. Tapizado en tela. No disponible en tela Cheyenne
8. Accesorios opcional: cojines lumbares, cojines "almohada"

SOFÁ GIANNI

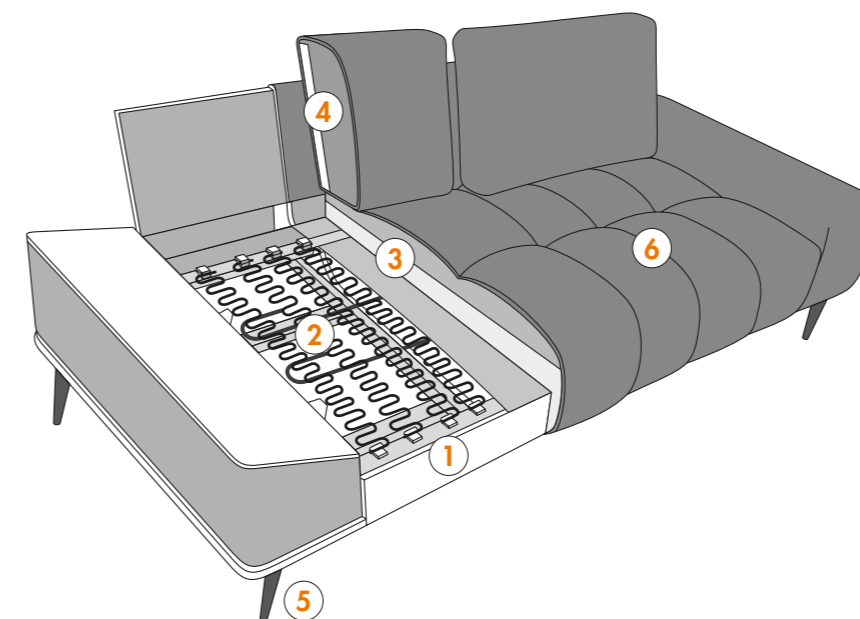

1. Estructura: Madera de haya.
2. Base del asiento: muelles de acero Nasag de elasticidad permanente cubiertos en fieltro.
3. Relleno del asiento: espuma PUR altamente elástica sin CFC. (Densidad 35 kg/m³) envuelta en visco-foam de alta calidad y mezcla de silicona.
4. Relleno del respaldo: cojines sueltos rellenos de escamas visco de alta calidad.
5. Patas: patas en metal negro cromado. Altura 17 cm.
6. Tapizado en tela o piel.

SOFÁ FORMA

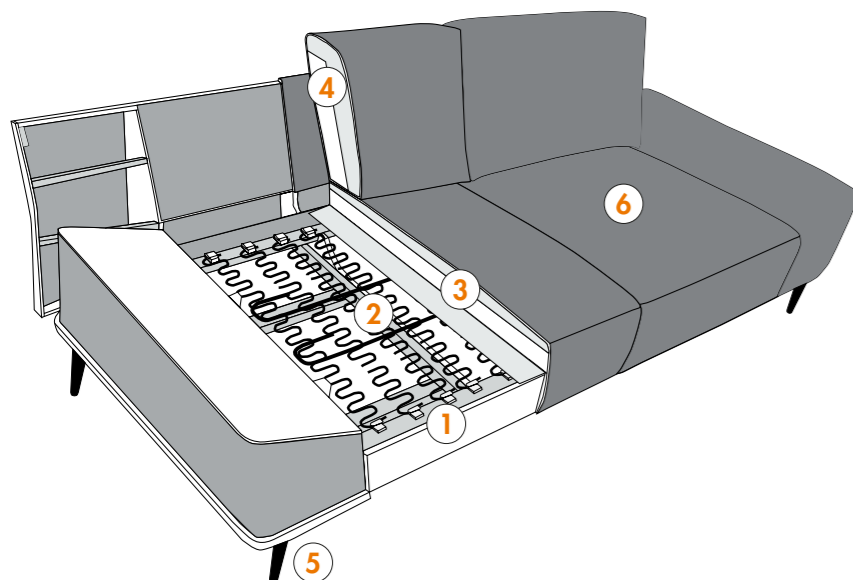

1. Estructura: Madera de haya.
2. Base del asiento: muelles en acero Nasag de elasticidad permanente cubiertos en fieltro.
3. Relleno del asiento: espuma PUR altamente elástica sin CFC (densidad 35 kg/m³) envuelta en "visco-foam" de alta calidad (densidad 45 kg/m³).
4. Relleno del respaldo: cojines sueltos rellenos de material altamente elástico. Espuma PUR sin CFC.
5. Patas: patas en metal negro o cromado. Altura 17 cm.
6. Tapizado: tapizado en tela o piel de un único color con ribete en contraste.
7. Accesorio opcional: reposacabezas, cojines lumbares, cojines "almohada".

SOFÁ TEMPLE, OASIS

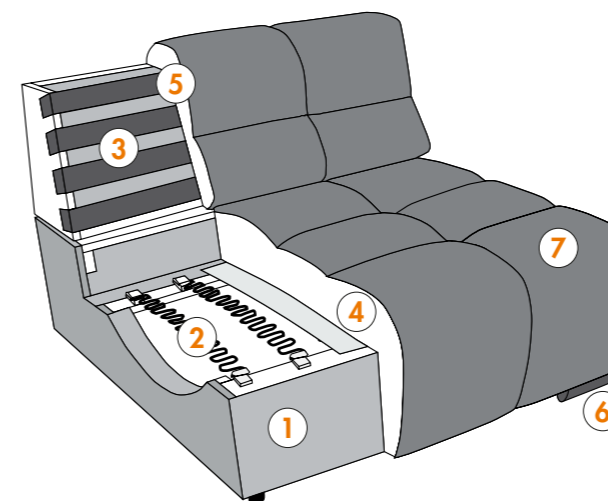

1. Estructura: Madera de haya.
2. Base del asiento: muelles de acero Nasag de elasticidad permanente cubiertos en fieltro.
3. Base del respaldo: Cinchas elásticas.
4. Relleno del asiento: espuma PUR altamente elástica sin CFC. (Densidad 35 kg/m³) envuelta en visco-foam de alta calidad (densidad 30 kg/m³).
5. Relleno del respaldo: espuma PUR de alta calidad sin CFC y de alta comodidad (densidad 25 kg/m³).
6. Patas: base de metal negro o cromado. Altura 4,5 cm.
7. Tapizado en tela.
8. Accesorio incluido: respaldo con movimiento de profundidad excepto en los elementos indicados.
9. Accesorio opcional: reposabrazos, cojín trasero con rollo, cojines lumbares, cojines "almohada".

Información técnica



SOFÁ CIELO

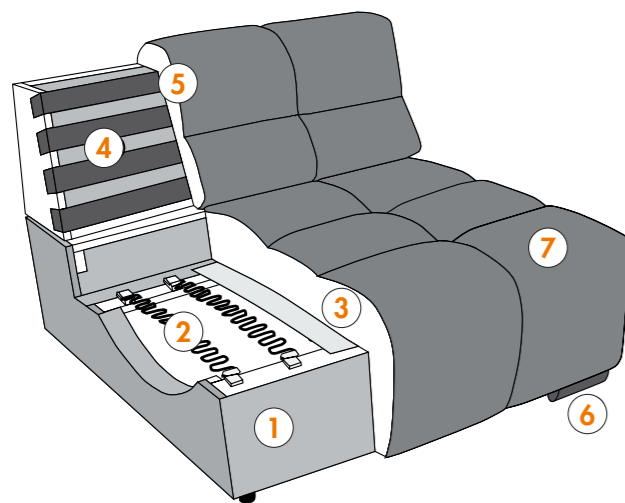

1. Estructura: Madera de haya.
2. Base del asiento: muelles de acero Nasag de elasticidad permanente cubiertos en fieltro.
3. Relleno del asiento: espuma PUR altamente elástica sin CFC. (Densidad 35 kg/m³) envuelta en visco-foam de alta calidad (densidad 30 kg/m³)
4. Base del respaldo: Cinchas elásticas.
5. Relleno del respaldo: espuma PUR de alta calidad sin CFC y de alta comodidad (densidad 25 kg/m³)
6. Patas: base de metal negro o cromado. Altura 4,5 cm.
7. Tapizado en tela.
8. Accesorio incluido: respaldo con movimiento de profundidad excepto en los elementos indicados.
9. Accesorio opcional: cojines lumbares, cojines "almohada"

SOFÁ PARMA

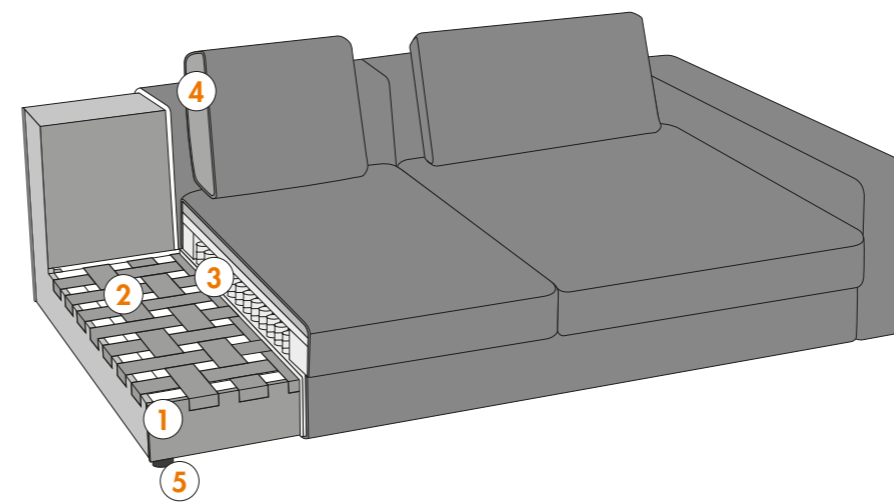

1. Estructura: Madera de haya.
2. Base del asiento: correas de tapicería flexibles.
3. Relleno del asiento: núcleo de muelles ensaquetados con extracto de espuma super suave sin senza CFC (densidad 30Kg/m³).
4. Relleno del respaldo: cojines sueltos rellenos de escamas de visco de alta calidad.
5. Patas: pies en plástico / altura 3cm.
6. Accesorios opcionales: reposacabezas, cojines lumbares.

SOFÁ PALACE, PALAZZINA

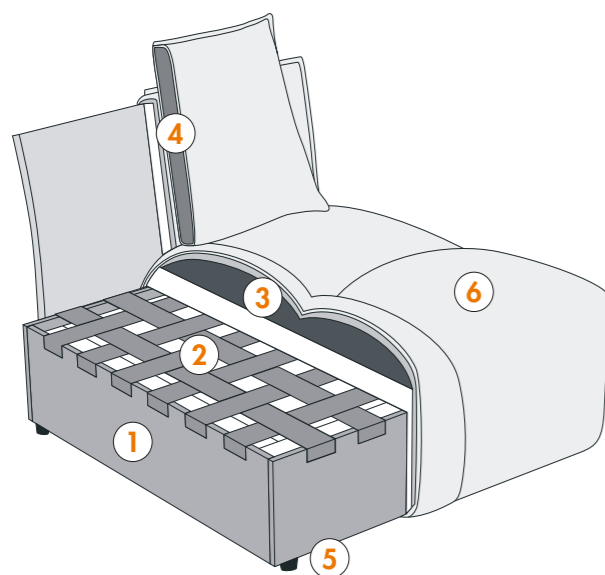

1. Estructura: Madera de haya
2. Base del asiento: correas de tapicerías flexibles.
3. Rellenos del asientos: espuma fría altamente elástica sin CFC (densidad 35 kg/m³) envuelta por cojín suave acolchado visco-elástico.
4. Relleno del respaldo: cojines sueltos con acolchado visco-elástico de alta calidad.
5. Patas: Soporte de plástico color negro de 3 cm de altura.
6. Tapizado: posibilidad de combinar dos colores entre la estructura y el asiento

SOFÁ VOLA, VOLARE

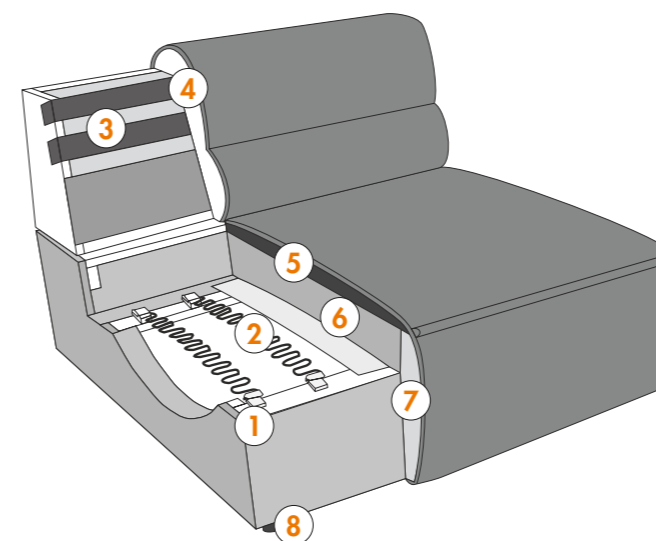

1. Estructura: Madera de haya.
2. Somier de láminas del asiento: Muelles ondulados de acero Nasag de elasticidad permanente con funda de fieltro.
3. Base del respaldo: Cinchas elásticas.
4. Relleno del respaldo: espuma fría altamente elástica sin CFC (densidad 25 kg/m³).
5. Composición del acolchado del asiento: funda de asiento suave con un interior de escamas de material visco (70%) y silicona (30%).
6. Relleno del asiento: espuma fría altamente elástica sin CFC (densidad 35 kg/m³) con capa de espuma "soft" sin CFC (densidad 30kg/m³).
7. Composición del acolchado del asiento: funda de espuma.
8. Patas: plástico negro/altura: 4,5 cm.
9. Accesorios opcionales: cojines lumbares, cojines sueltos.

SOFÁ BERRY

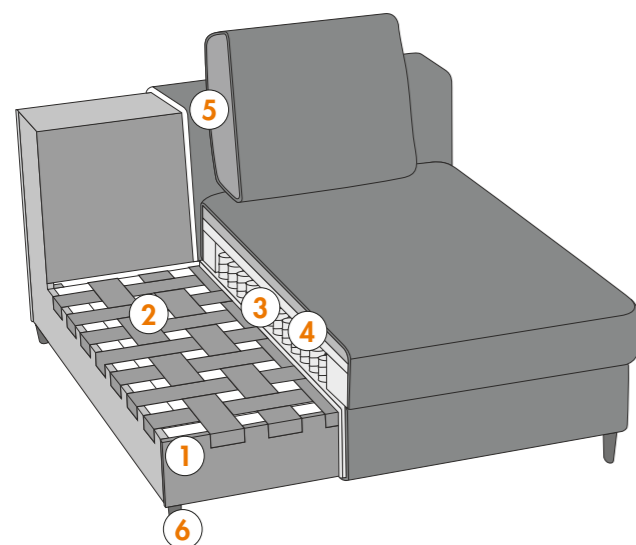

1. Estructura: Madera de haya.
2. Base del asiento: correas de tapicerías flexibles.
3. Relleno del asiento: núcleo con correas elásticas y muelles ensaquetados, puntos con una capa de espuma suave sin FCKW de alta resistencia (densidad 30 kg/m³).
4. Composición del acolchado del asiento: funda de asiento suave con interior de escamas en material viscoelástico y silicona.
5. Relleno del respaldo: cojines sueltos rellenos de escamas de visco de alta calidad.
6. Patas: en acero inoxidable / altura 6 cm.
7. Accesorios opcionales: cojín lumbar, reposacabezas.

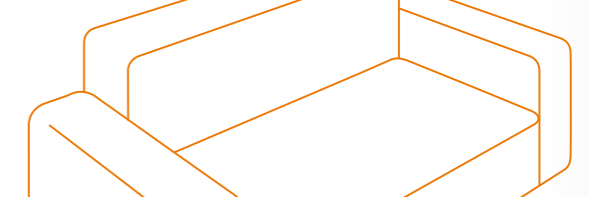

POUF **RONDO**



Poufs de forma redondeada con dos alturas disponibles. Tapizado en tela con ribete en contraste.

Dimensiones

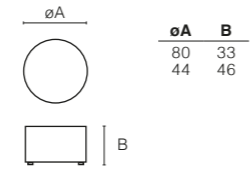

POUF **SADDLE**



Pouf elegante de forma cuadrada con ribete en contraste.

Dimensiones

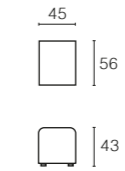

POUF **STORE**



Pouf de forma cuadrada con práctico contenedor.

Dimensiones

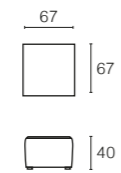

POUF **POUF**



Poufs de forma cuadrada con dos alturas disponibles. Tapizados en capitoné.

Dimensiones

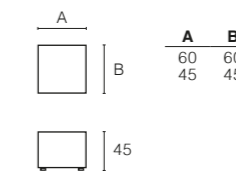

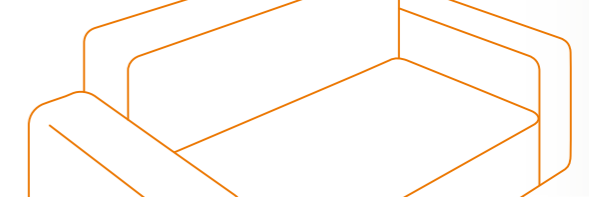

MESA BRIGHTON

Mesa de centro desplegable con estructura de aluminio y sobre laminado de 18 mm. Con un práctico contenedor en su interior. Gran recorrido en la apertura lo que permite un uso cómodo de la mesa.

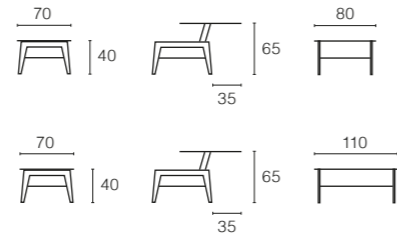

Sobre
MELAMINA



Blanco Mate Tortora Mate Gris Ardesia Nogal Nogal Ardesia

Patas y Estructura
ALUMINIO

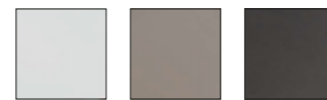

Blanco Tortora Gris Ardesia

MESA DE CENTRO NORDIC

Familia de mesas de centro con patas en aluminio pintado y sobre en cristal al ácido o mármol.

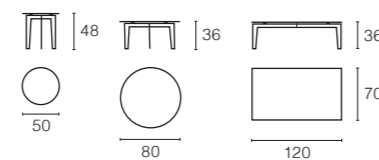

Sobre
CRISTAL AL ÁCIDO



Blanco Tortora Negro

MARMOL



Blanco Carrara Negro Marquina

Patas y Estructura
ALUMINIO



Blanco Tortora Gris Ardesia

MESA DE CENTRO SHAPE

Familia de mesas de centro en diferentes medidas. Patas y sobre en aluminio pintado texturizado.

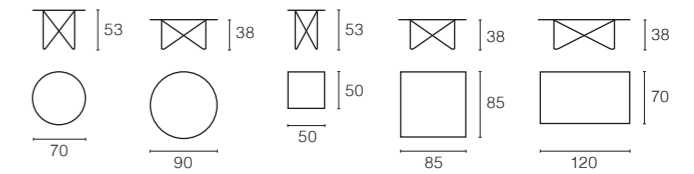

Acabados

METAL

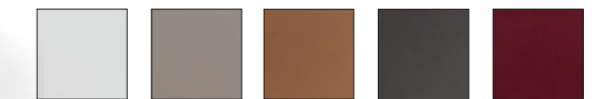

Blanco Tortora Cobre Gris Ardesia Marsala



Dorado Azul Petroleo

MESA DE CENTRO ADN MARMOL

Conjunto de mesas de centro y consola con estructura metálica.

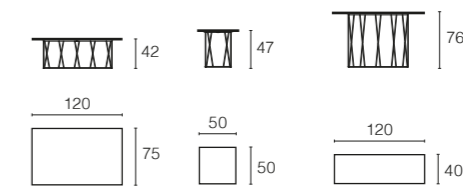

ADN MESAS

ADN CONSOLA

Sobre
MÁRMOL



Negro Marquina Verde Guatemala Blanco Carrara

Estructura
ACERO



Negro

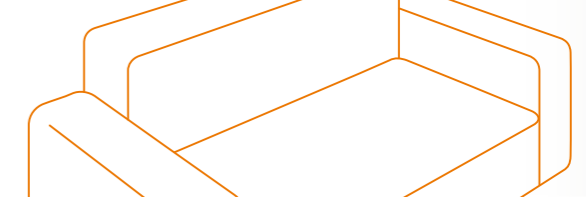

MESA DE CENTRO **QUADRAT** MARMOL

Mesa de centro desplegable con estructura de aluminio y sobre laminado de 18 mm. Con un práctico contenedor en su interior. Gran recorrido en la apertura lo que permite un uso cómodo de la mesa.

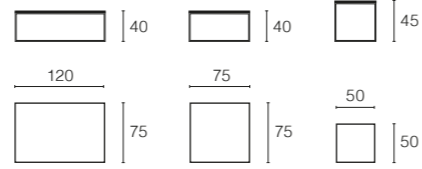

Sobre
MÁRMOL

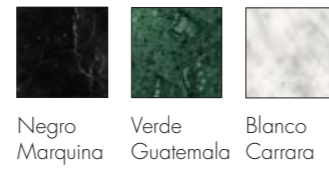

Estructura
ACERO



MESA DE CENTRO **OUTLINE**

Familia de mesas de centro con patas metálicas en negro y sobre en aluminio pintado metalizado.

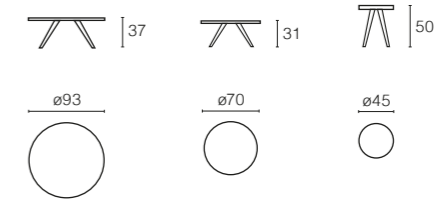

Sobre
ALUMINIO

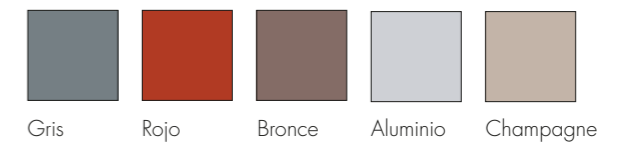

Patas
METAL



MESA DE CENTRO **QUADRAT**

Conjunto de mesas de centro con estructura metálica pintada o cromada y sobre en roble natural o polywood blanco.

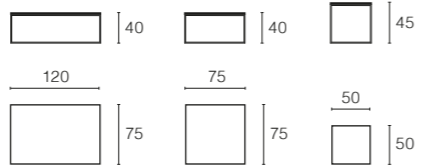

Sobre
MADERA

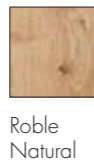

Estructura
ACERO



CONCRET

Tapiceria

SOFÁS CAMA

TOMMY	89
ERIC	93
STAN	95
JACK	97
<hr/>	
TAPIZADOS	125

CAMAS

VICTORIA PLAIN	101
VICTORIA QUILT	103
NAXOS	105
BAHAMAS	107
MARTINICA	109
PACIFIC - MALIBU	111
MARIANNE	113
PHUKET	115
SAMAR	117
DEVON	119
<hr/>	
SOMIERES	121
CARACTERÍSTICAS TÉCNICAS	123
TAPIZADOS	125

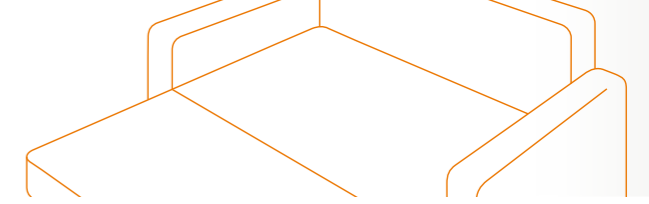



Standard: somier laminas de madera

Opcional: cojines lumbares.



SOFÁ CAMA Y POUF TOMMY

Sofá cama de diseño joven, TOMMY se transforma en una cama con somier de láminas a través de un mecanismo simple, con apertura frontal; el colchón de espuma de poliuretano está enfundado con tela de algodón acolchado. Somier ortopédico de laminas en multichapado curvado de haya evaporada. Apertura y cierre del mecanismo en un solo paso.

Ver opciones de tapizados en páginas 124 y 125.

Dimensiones

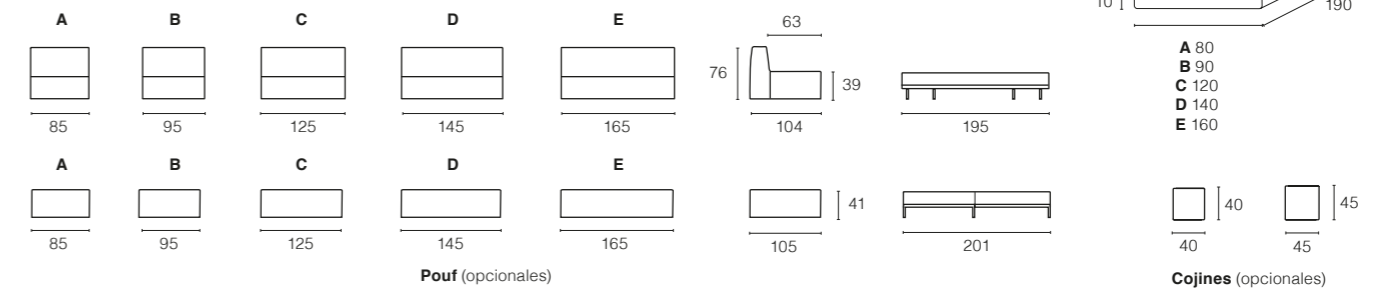

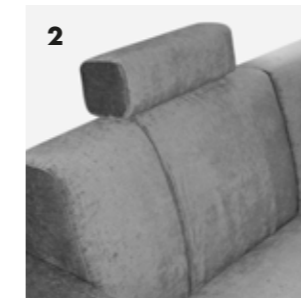
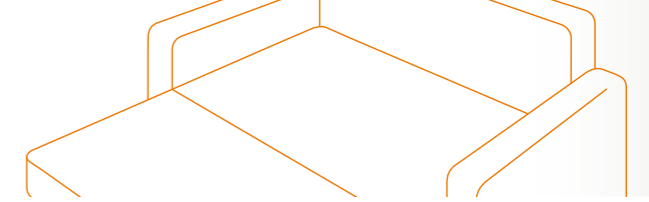

- 1. Standard: somier de malla electro-soldada.
- 2. Opcional: reposacabezas.
- 3. Opcional: mecanismo para facilitar el movimiento del sofá.



SOFÁ ERIC

ERIC se integra con clase en todos los ambientes. Con una simple rotación del respaldo y sin mover ningún cojín, ERIC se transforma en una confortable cama con colchón de 195 cm. El revestimiento es completamente desenfundable y lavable según la tela escogida. ERIC está disponible también en versión fija y es completamente desmontable para facilitar el transporte.

Ver opciones de tapizados en páginas 124 y 125.

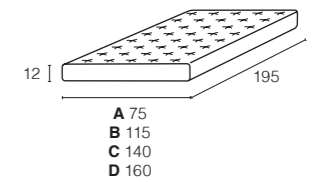

Dimensiones

ERIC / ERIC 4

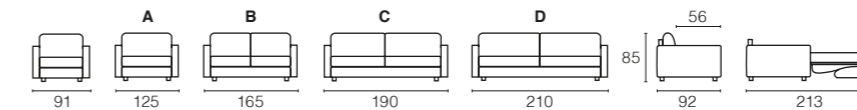

ERIC 2 / ERIC 6

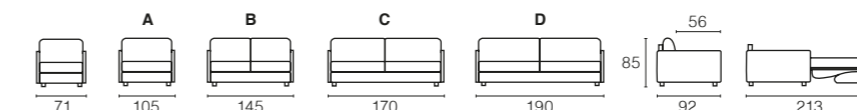

ERIC 3

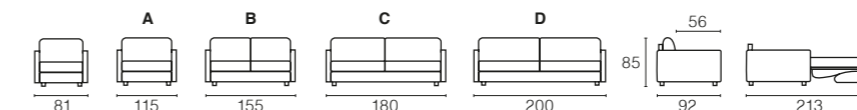

ERIC 5

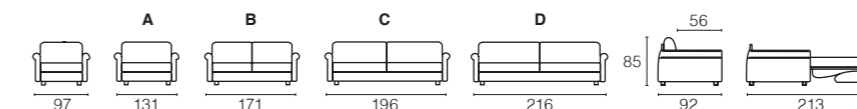

ERIC 8

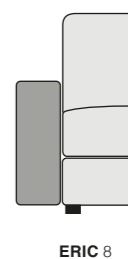
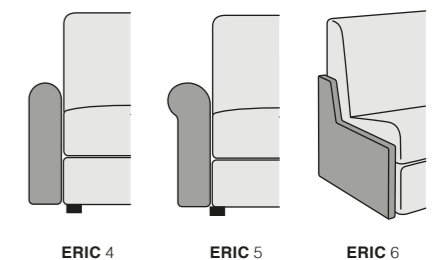
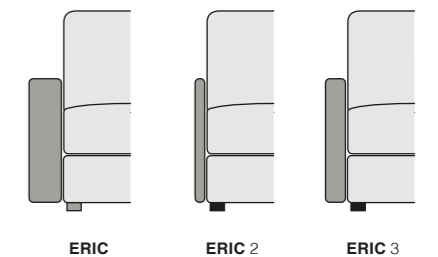
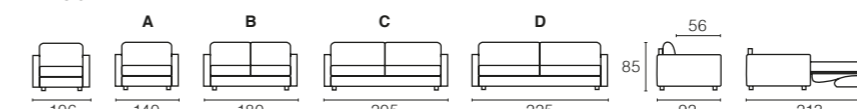

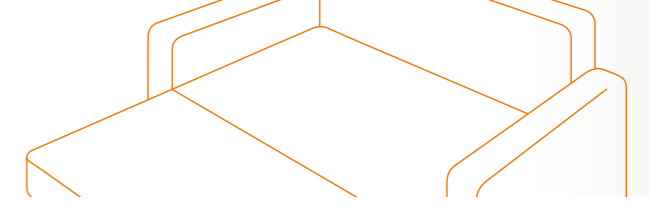

Standard: somier de malla electro-soldada.



Opcional: mecanismo para facilitar el movimiento del sofá.



SOFA STAN

Stan es un sofá de línea esencial que se integra en todos los ambientes. Desenfundable y lavable según tejido escogido. Con una simple rotación del respaldo y sin mover ningún cojín, STAN se transforma en una confortable cama con colchón de 200 cm. de largo.

STAN está disponible en versión fija y es completamente desmontable para su fácil transporte.

Ver opciones de tapizados en páginas 124 y 125.

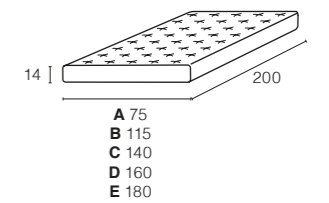

Dimensiones

Model	A	B	C	D	E	Depth	Height	Width
STAN	116	156	181	201	221	85	56	213
STAN 1 / STAN 4	125	165	190	210	230	85	56	213
STAN 2 / STAN 6	105	145	170	190	210	85	56	213
STAN 3	115	155	180	200	220	85	56	213
STAN 5	131	171	196	216	236	85	56	213
STAN 8	140	180	205	225	245	85	56	213

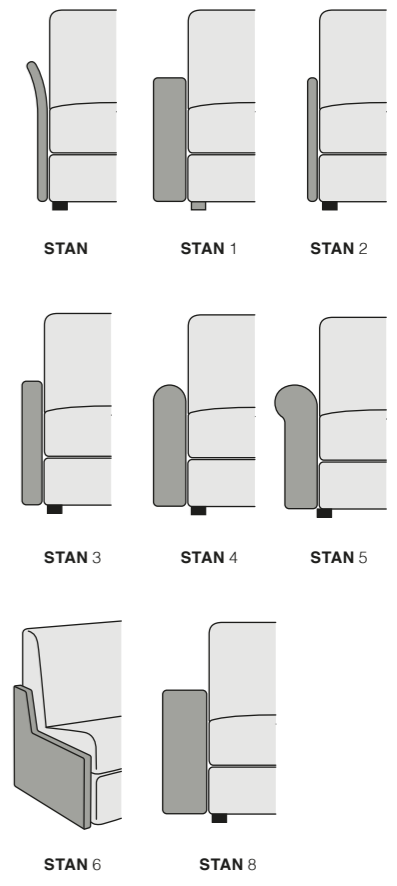



JACK



JACK 1



JACK 2



JACK 3



JACK 4



JACK 5



JACK 6



JACK 7



JACK CLASSIC



JACK CLASSIC 1



JACK CLASSIC 2



JACK CLASSIC 4



JACK CLASSIC 5



JACK CLASSIC 6

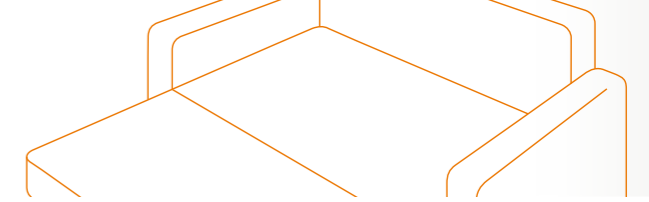

SOFA CAMA JACK

JACK es un programa de sofás cama prácticos y versátiles, que incluye modelos con un diseño sobrio o romántico, ajustándose a cualquier necesidad. JACK está disponible en varias versiones: sofá, chaise longue, cama con somier de láminas, con cabecero, con piecero, individual, doble, con cajones (opcionales) y arcón. JACK puede ser enriquecido con diversos tipos de cojines (opcionales) de acuerdo a su gusto, y una colcha para la segunda cama (opcional).

Ver opciones de tapizados en páginas 124 y 125.

Dimensiones

JACK

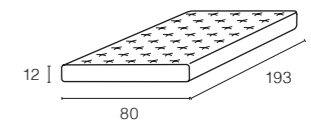
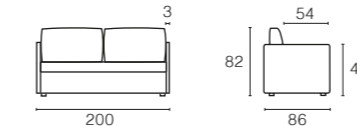

JACK 1

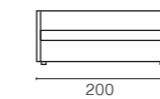

JACK 2

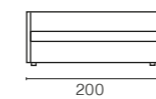

JACK 3

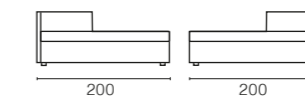

JACK 4

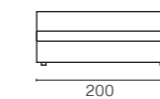

JACK 5

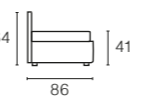

JACK 6

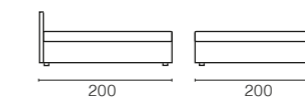

JACK 7

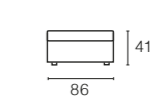
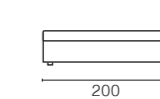

JACK CLASSIC

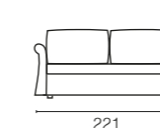

JACK CLASSIC 1



JACK CLASSIC 2

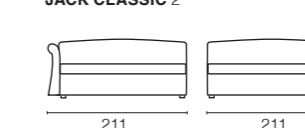

JACK CLASSIC 3

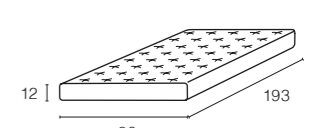
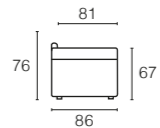

JACK CLASSIC 4

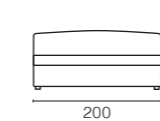

JACK CLASSIC 5

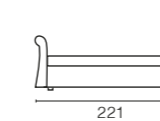

JACK CLASSIC 6

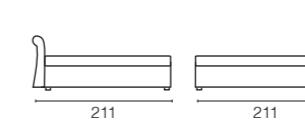

JACK CLASSIC 7

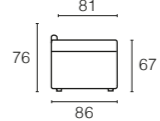

VICTORIA PLAIN

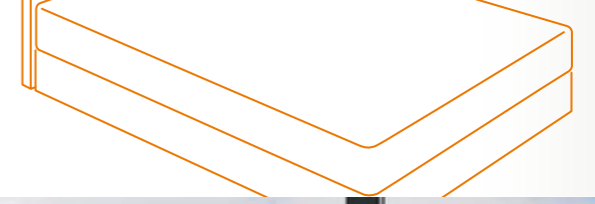

VICTORIA QUILT



NAXOS



BAHAMAS



BAHAMAS PLAIN



BAHAMAS QUILT



Pies de madera recubiertos de tela.

MARTINICA



PACIFIC MALIBU



PACIFIC

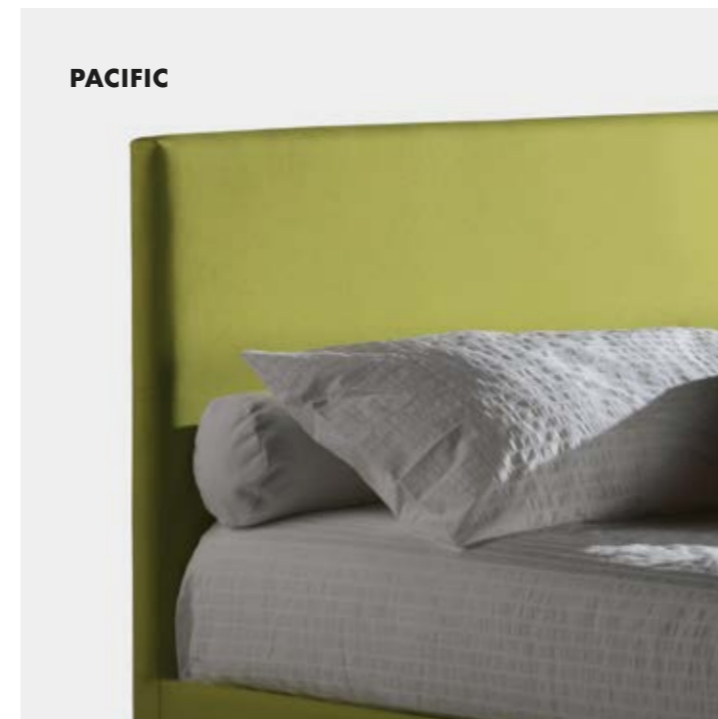

MALIBU



MARIANNE



PHUKET



SAMAR

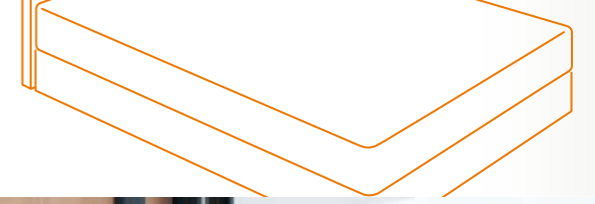

DEVON

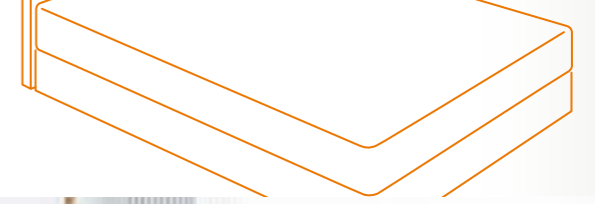

SOMIER

Las camas de CONCRET vienen con somier incluido. Somier partido. Cuadro perimetral en tubo rectangular de 40x30x1,5 mm; somier ortopédico en láminas de multicapas de haya, con opción de reguladores de flexibilidad.

Las camas de CONCRET se entregan totalmente desmontadas, incluso el somier va partido, para su facilidad en el transporte y manipulación.



Somier opcional con lamas articulables.



Reguladores de flexibilidad opcionales

En todos los modelos la cama puede completarse con un amplio contenedor con dos sistemas de apertura, el sistema standard o el sistema Komodo con dos movimientos (abierto y levantado en posición horizontal sobresale 32 cm de la cama) que permite hacer la cama de pie.



CAMA



CAMA CON CONTENEDOR



CAMA CON CONTENEDOR KOMODO

Información técnica

CAMAS

Cama tapizada sistema "ahorra espacio" ya que el colchón se apoya sobre la estructura de la cama sin perder espacio. Somier incluido. Desenfundable.

Gran posibilidad de medidas. Pies en madera natural o wengué. Posibilidad de pies en cromado (con suplemento). Posibilidad de somier con contenedor. Disponible sólo el cabezal.

Ver opciones de tapizados en páginas 110 y 111.

Dimensiones

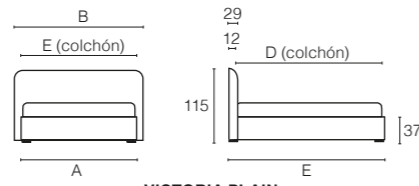

VICTORIA PLAIN

Cama			Colchón	
A	B	C	E	D
82	122	208	80	190
82	122	218	80	200
93	133	208	90/91	190
93	133	218	90/91	200
102	142	218	100	200
122	162	218	120	200
142	182	208	137	191
142	182	208	140	190
142	182	218	140	200
155	195	208	150	190
155	195	221	153	203
162	202	208	160	190
170	210	213	160	190 XL
162	202	218	160	200
170	210	223	160	200XL
172	212	218	170	200
180	220	223	170	200 XL
182	222	218	180	200
190	230	223	180	200 XL
185	225	221	183	203
195	235	231	193	213
202	242	218	200	200

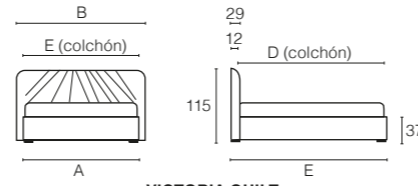

VICTORIA QUILT

Cama			Colchón	
A	B	C	E	D
82	122	208	80	190
82	122	218	80	200
93	133	208	90/91	190
93	133	218	90/91	200
102	142	218	100	200
122	162	218	120	200
142	182	208	137	191
142	182	208	140	190
142	182	218	140	200
155	195	208	150	190
155	195	221	153	203
162	202	208	160	190
170	210	213	160	190 XL
162	202	218	160	200
170	210	223	160	200XL
172	212	218	170	200
180	220	223	170	200 XL
182	222	218	180	200
190	230	223	180	200 XL
185	225	221	183	203
195	235	231	193	213
202	242	218	200	200

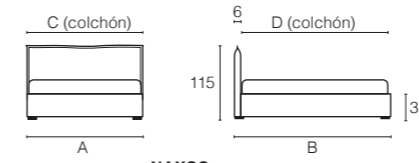

NAXOS

Cama		Colchón	
A	B	C	D
82	205	80	190
82	215	80	200
93	205	90/91	190
93	215	90/91	200
102	215	100	200
122	215	120	200
142	205	137	191
142	205	140	190
142	215	140	200
155	205	150	190
155	218	153	203
162	205	160	190
170	210	160	190 XL
162	215	160	200
170	220	160	200XL
172	215	170	200
180	220	170	200 XL
182	215	180	200
190	220	180	200 XL
185	218	183	203
195	228	193	213
202	215	200	200

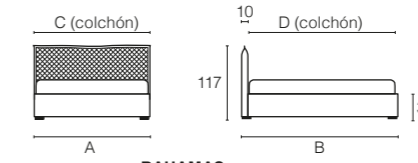

BAHAMAS

Cama		Colchón	
A	B	C	B
82	205	80	190
82	215	80	200
93	205	90/91	190
93	215	90/91	200
102	215	100	200
122	215	120	200
142	205	137	191
142	205	140	190
142	215	140	200
155	205	150	190
155	218	153	203
162	205	160	190
170	210	160	190 XL
162	215	160	200
170	220	160	200XL
172	215	170	200
180	220	170	200 XL
182	215	180	200
190	220	180	200 XL
185	218	183	203
195	228	193	213
202	215	200	200

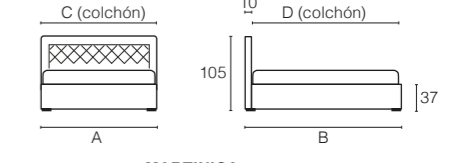

MARTINICA

Cama		Colchón	
A	B	C	D
82	205	80	190
82	215	80	200
93	205	90/91	190
93	215	90/91	200
102	215	100	200
122	215	120	200
142	205	137	191
142	205	140	190
142	215	140	200
155	205	150	190
155	218	153	203
162	205	160	190
170	210	160	190 XL
162	215	160	200
170	220	160	200 XL
172	215	170	200
180	220	170	200 XL
182	215	180	200
190	220	180	200 XL
185	218	183	203
195	228	193	213
202	215	200	200

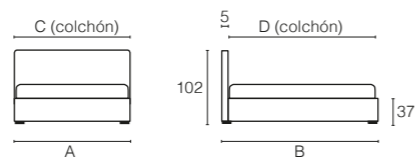

PACIFIC

Cama		Colchón	
A	B	C	D
82	200	80	190
82	210	80	200
93	200	90/91	190
93	210	90/91	200
102	210	100	200
122	210	120	200
142	200	137	191
142	200	140	190
142	210	140	200
155	200	150	190
155	213	153	203
162	200	160	190
170	205	160	190 XL
162	210	160	200
170	215	160	200 XL
172	210	170	200
180	215	170	200 XL
182	210	180	200
190	215	180	200 XL
185	213	183	203
195	223	193	213
202	210	200	200

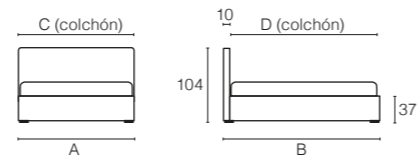

MALIBU

Cama		Colchón	
A	B	C	D
82	205	80	190
82	215	80	200
93	205	90/91	190
93	215	90/91	200
102	215	100	200
122	215	120	200
142	205	137	191
142	205	140	190
142	215	140	200
155	205	150	190
155	218	153	203
162	205	160	190
170	210	160	190 XL
162	215	160	200
170	220	160	200XL
172	215	170	200
180	220	170	200 XL
182	215	180	200
190	220	180	220 XL
185	218	183	203
195	228	193	213
202	215	200	200

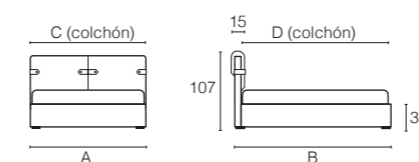

MARIANNE

Cama		Colchón	
A	B	C	B
82	210	80	190
82	220	80	200
93	210	90/91	190
93	220	90/91	200
102	220	100	200
122	220	120	200
142	210	137	191
142	210	140	190
142	220	140	200
155	210	150	190
155	223	153	203
162	210	160	190
170	215	160	190 XL
162	220	160	200
170	225	160	200 XL
172	220	170	200
180	225	170	200 XL
182	220	180	200
190	225	180	200 XL
185	223	183	203
195	233	193	213
202	220	200	200

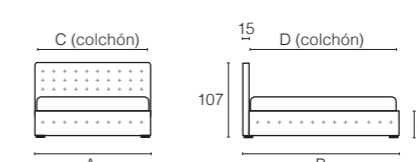

PHUKET

Cama		Colchón	
A	B	C	D
87	210	80	190
87	220	80	200
98	210	90/91	190
98	220	90/91	200
107	220	100	200
127	220	120	200
147	210	137	191
147	210	140	190
147	220	140	200
160	210	150	190
160	223	153	203
167	210	160	190
170	215	160	190 XL
167	220	160	200
175	225	160	200 XL
177	220	170	200
185	225	170	200 XL
187	220	180	200
195	225	180	200 XL
190	223	183	203
200	233	193	213
207	220	200	200

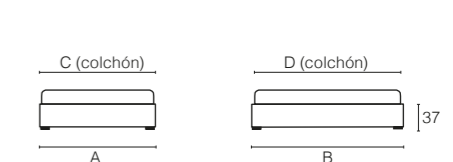

SAMAR - DEVON

Cama		Colchón	
A	B	C	D
82	195	80	190
82	205	80	200
93	195	90/91	190
93	205	90/91	200
102	105	100	200
122	205	120	200
142	195	137	191
142	195	140	190
142	205	140	200
155	195	150	190
155	208	153	203
162	195	160	190
170	200	160	190 XL
162	205	160	200
170	210	160	200 XL
172	205	170	200
180	210	170	200 XL
182	205	180	200
190	210	180	200 XL
185	208	183	203
195	218	193	213
202	205	200	200



Acabados

TAPIZADOS PARA SOFÁS CAMA Y CAMAS



MOP

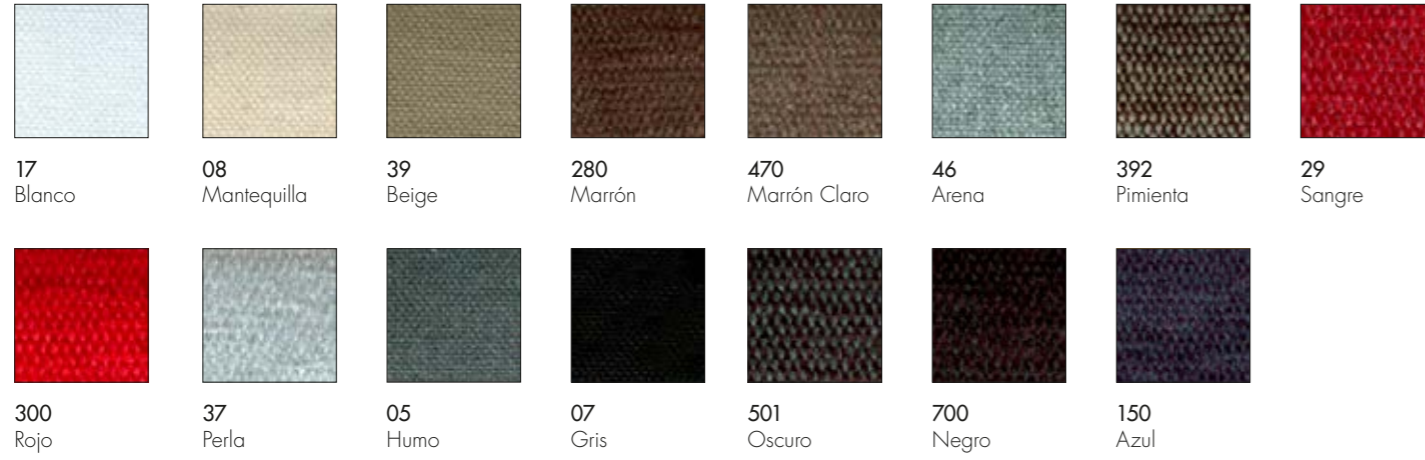

FICUS



MELANICA

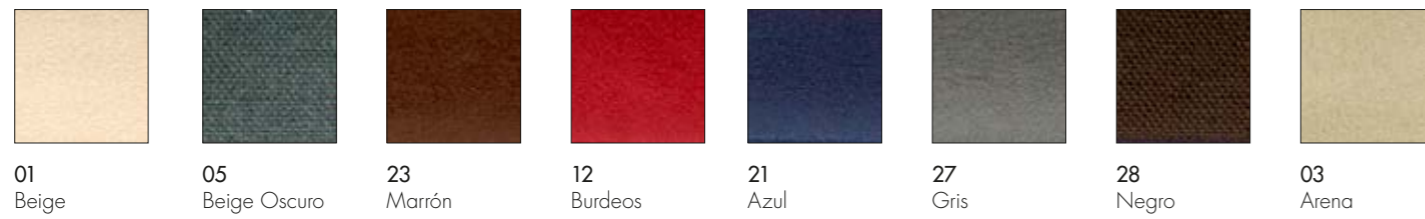

EULIMA

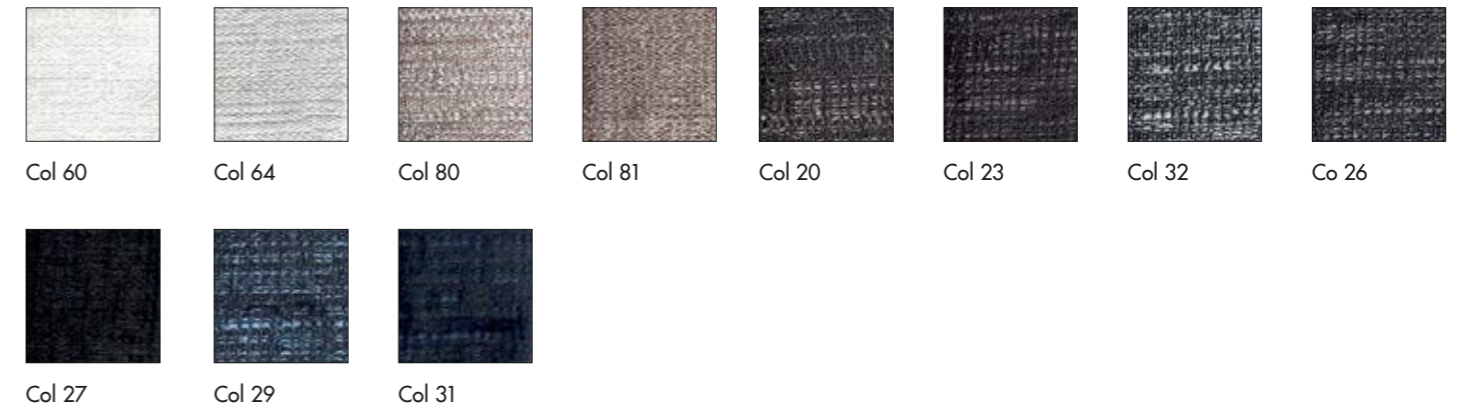

IRUS





C/ Joan Torruella i Urpina, 13 · 08758 Cervelló · Barcelona
Tel. 34-936 600 640 · Fax 34-936 842 716
vilaimport@vilaimport.com

www.concret-design.com
www.vilaimport.com

